



FIMER

Solar inverter solutions for Utility applications

"We are committed to providing our contribution in order to achieve the global community's world, as the creation of a sustainable future."

In a global scenario where the demand for renewable energy is constantly growing, we are among the leaders concerning the manufacturing of energy conversion solutions worldwide. We are committed to make our customers able to provide greener and smarter energy.

The focus of our goal is based on our experience as the world's leading manufacturer of solar inverters. Therefore our wish is to foster the materialization of an era marked by clean and sustainable energy, through innovative new concepts in both energy production and consumption.

Our headquarters in Vimercate (Italy) are designed to be an example of sustainability, with a 1 MW photovoltaic system and the best technologies in the field of geothermal energy.

Thanks to these characteristics, today we are one of the few Zero impact companies in the world.

Filippo Carzaniga

Chairman

Table of contents

- 04 Our brand, our roots, our future**
- 06 A Global reality, Made in Italy**
- 11 FIMER string inverter solutions**
- 39 FIMER central inverter solutions**
- 74 PVS980 central inverters connectivity solutions**
- 78 Accessories**
- 84 Life cycle services**
- 87 FIMER Friends Days**
- 88 360° Virtual Tour experience**

Our brand, our roots, our future

Our vision is to shape a **new and powerful energy model** that uses the power of the sun to drive progress and prosperity for a cleaner and sustainable world. As a global leader in solar inverter technology, with a 100% Italian supply chain, we have the energy to make positive change happen. We are committed to building value for future generations using **clean energy** as a response to the world's growing energy needs.

We do it in a sustainable, innovative and dynamic way, through a complete portfolio of photovoltaic solutions for energy conversion and storage, and e-mobility solutions for electric vehicles. Through such extensive range of products, we share our **brave, new vision** with the world.

Our DNA and our core values all reflect our vision and mission:

Responsibility

Every day we strive to offer our customers reliable and state-of-the-art solutions and to build a world where energy is used in a sustainable manner for future generations.



Passion

We never stop. We focus on expanding and improving our know-how and expertise to drive growth. This is reflected in the passion we put into our work, into the solutions we create and into the technologies we design every day and in the Service that we provide to our customers.

Professionalism

We are close to our customers, to ensure the quality and distinctive excellence of our solutions. We like to leave a mark. A guarantee for those who invest in our expertise and professionalism.



Flexibility

We are quick to interpret changes and fast at adapting to market developments. We are able to constantly improve and work hard to be number one when it counts, where it counts. Our skills and our ability to make the most of change are an integral part of our way of being.

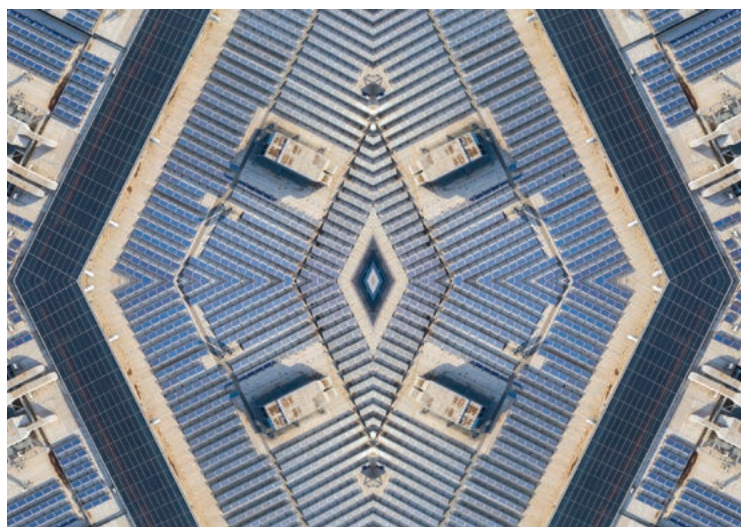



Vimercate Headquarters

All over the world, our work contributes to reducing CO² emissions. Our global Headquarters in Vimercate are designed to set an example of efficiency, sustainability and technology that has made us one of the few companies with Zero Impact, powered by a 1 MW photovoltaic system constructed with highly sustainable materials. Our HQ in Vimercate features an area specializing in cutting-edge carpentry and logistics. We constantly invest in high-precision machines and technologies, to guarantee the quality of our solutions manufactured both in Vimercate and Terranuova Bracciolini.

Terranuova R&D and manufacturing site

Our Terranuova Bracciolini branch features an innovative research and development department, several technologically advanced laboratories and highly specialized production areas, making FIMER an Italian technology leader.



A Global reality, Made in Italy

Operating in more than 20 countries, with over than 1.100 collaborators and one of the broadest solutions portfolio, we are now one of the leading manufacturers of energy conversion systems, ready to listen and face every challenge in every corner of the world.

Research & Development, the main production plants and all the main decision-making processes take place in Italy. We have a common goal that goes beyond all borders: to expand Italian technological excellence to the whole world.

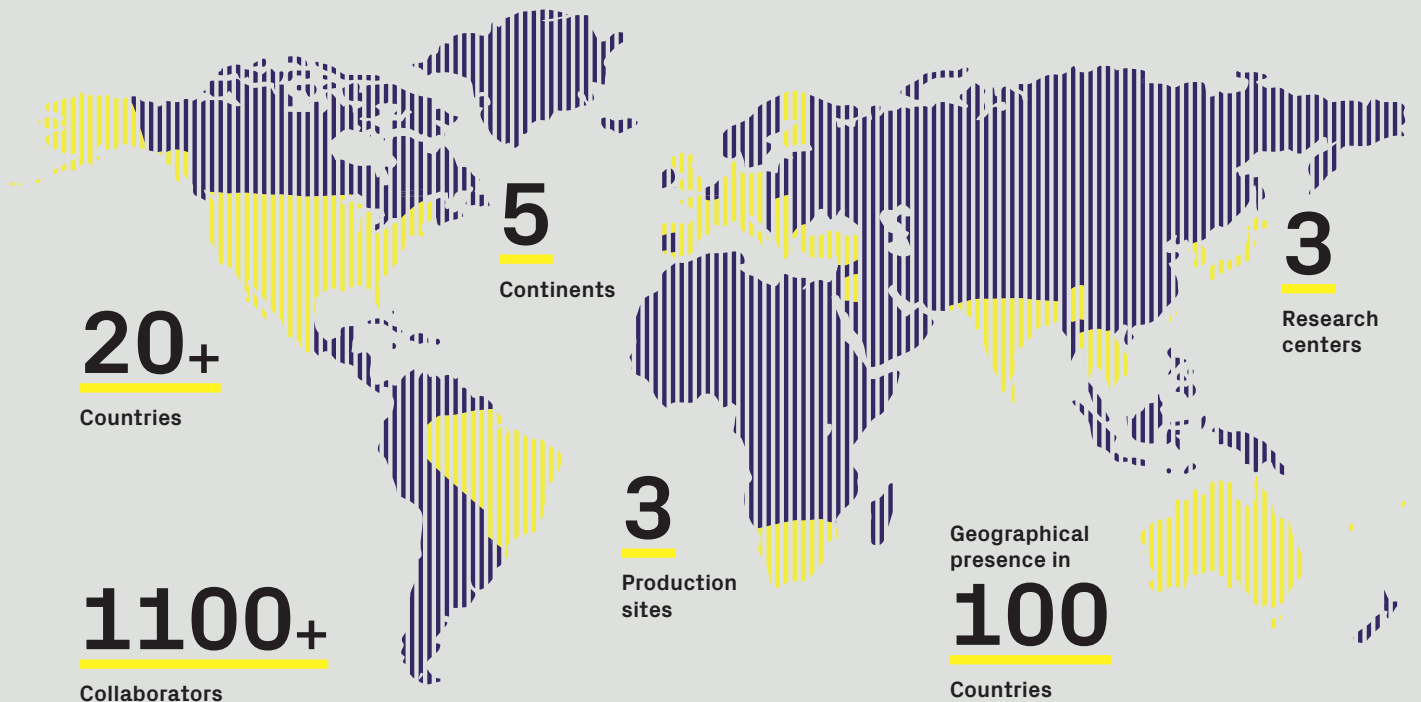

Our solutions are based on over 80 years of experience and continuous technological advances. Standardized, certified and expandable: the production processes applied and the plants in which the inverters are manufactured play a key role in ensuring the high quality of our offer. Engineering excellence, rigorous quality and testing standards are corroborated by our global certifications; we strive to achieve the highest levels of quality in every aspect of our business.

Certified Partners to ensure high quality and a reliable service at a global level.

The excellence of the Made in Italy concept also extends to our Service Partner Network. We select the Partners according to their professionalism and reliability criteria and we offer pre-and post-sales services, Customer support, webinars and constant education. We have a network of certified and trained partners, who know the market inside out and are available to propose our solar and e-mobility solutions, tailored to local regulations and specific needs.

FIMER solar inverter solutions for Utility application

String inverter solutions

FIMER string inverter solutions enable the smart and cost-effective designs for industrial and small utility-scale PV power plants by maximizing energy yields even in challenging land shapes and locations. FIMER's offering for these plants includes complete plug and play inverter solutions and MV stations. The string inverter solutions can be utilized also in PV power plants of commercial and industrial buildings to minimize the needed investment.



Power block size (kW)

Central inverter solutions

In large ground-mounted multi-megawatt photovoltaic (PV) power plants the PV modules are typically installed uniformly mounted at ground level, either on fixed-tilted structures facing the sun or on tracking devices. For these land-based power plants FIMER central inverters offer the most cost-effective and efficient solution for PV energy generation by feeding electricity directly to the medium voltage (MV) power distribution network (i.e. grid).

FIMER's offering for large plants includes a wide range of central inverter stations and turnkey solutions.



Power block size (kW)

Meet your bankability and profit targets with FIMER solar inverter solutions

Maximize the return on your PV investment with solar inverter solutions designed for high total efficiency, reliability and ease of installation.

Proven solutions with long-term reliability

FIMER inverter solutions utilize decades of experience and advances in inverter and power converter technology. Together with FIMER's engineering know-how and complete product portfolio for PV power plants, FIMER inverter solutions provide optimized plug and play experience for quick and reliable connection of the PV plant to the grid.

Global presence with local support

FIMER solar inverters solutions are supported through a worldwide sales and services network. The high-performance FIMER solutions provide highly reliable, cost-effective and bankable utility-scale PV power plants. Wherever your project is located, FIMER is your reliable partner to support you over the whole lifetime of your plant.

FIMER solar inverter solutions – features and benefits

- Plug and play solutions, designed for large-scale solar power generation enabling rapid installation with cost-effectiveness
- All-in-one design ensuring maximum uptime of the plant with minimum total investment
- High reliability and efficiency with low auxiliary power consumption resulting in high total performance
- Modular and serviceable systems increased uptime
- Proven technology and reliable components securing long operating life and attractive return on investment
- Smart connectivity with controllability for digital grid compatibility
- Global life cycle services and support

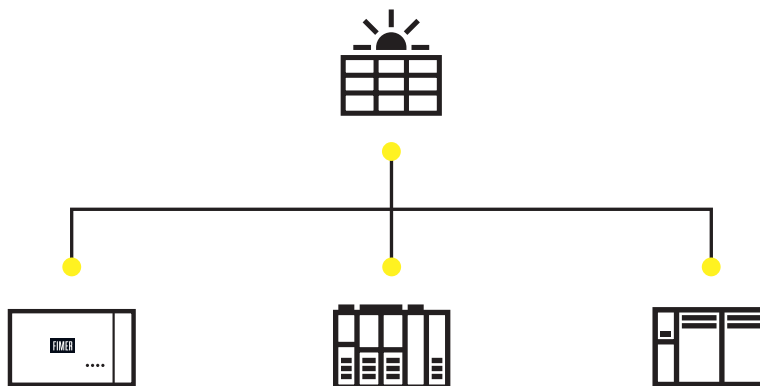





FIMER string inverter solutions

The future of energy is anchored to renewable energy sources like photovoltaics that have already driven the transformation in the way energy is produced, consumed and provided through modern distribution grids. Photovoltaics are already one of the most cost-effective energy sources in many regions of the world. When they complement with digital technologies the benefits for users are at the maximum scale.

FIMER's offering includes three-phase string inverters as well as string inverter solutions with medium voltage (MV) stations. The string inverter solutions can be used in PV power plants of commercial and industrial buildings as well as in ground mounted applications.

Bright future ahead for decentralized power generation

Designed to optimize the total cost of ownership in PV projects, our inverters guarantee high total efficiency and reliability. The high power density and reduced installation and maintenance efforts enhance overall cost efficiency.

Thanks to their modularity and flexibility, our string inverters are the ideal solution for simplified system planning and design.

Complete string inverter solutions for decentralized energy at its full potential

Economically attractive solutions can also be built in remote locations or places where land shapes create additional challenges for the plant design. Even multi-megawatt size installations can be designed with technically and

economically cost-effective results, thanks to our complete string inverter solutions. They include all MV components as well as a series of cloud based advanced communications services, which simplify the integration in smart environments.

Thanks to our string inverter solutions for decentralized applications, many companies can achieve greater efficiency and sustainable growth, today and tomorrow.

Features and benefits

- Configurable all-in-one design with built-in and monitored protection devices providing reduced system cost
- Wide input voltage range with multiple MPPT (Maximum Power Point Tracking) enabling flexibility for system designers
- High total efficiency for rapid return on investment
- Advanced grid support functions and compatibility with grid codes
- Safe and intuitive user and service interface enabling fast and easy commissioning
- Robust enclosure with IP65 rating for outdoor installations

String inverter

PVS-175-TL

up to 185 kW

The PVS-175-TL is FIMER's innovative three-phase string inverter, delivering a six-in-one solution to enhance and optimize solar power generation for ground mounted utility-scale applications.

High power density

This new high-power string inverter with the highest power density within the 1500 Vdc segment, delivers up to 185 kVA at 800 Vac. This not only maximizes the ROI for ground-mounted utility-scale applications but also reduces Balance of System costs (i.e. AC side cabling) for small to large scale, free field ground mounted PV installations.

Design flexibility

The inverter comes equipped with 12 MPPT, the highest available in the market, assuring maximum PV plant design flexibility and increasing yields also in case of complex installations.

Installer friendly design

Quick and easy installation, thanks to plug and play connectors, as the existing PV module's mounting systems can be used to install the inverters, thus saving time and cost on site preparation and hire of plant.

The fuse and combiner free design eliminates the need for external components, such as separate DC combiner boxes and AC first level combiners, thanks to the integrated DC disconnect and AC wiring compartment with optional AC disconnect.

The Advanced Cooling Concept preserves the lifetime of the system and minimizes O&M costs thanks to internal heavy-duty inverter cooling fans. These can be easily removed during scheduled maintenance cycles whilst the power module can be easily replaced without removing the wiring box.

Advanced communication for O&M

Standard wireless access from any mobile device makes the configuration of inverter and plant easier and faster. Improved user experience thanks to a built-in User Interface (UI) enables access to advanced inverter configuration settings.

The Installer for Solar Inverters mobile APP and configuration wizard enable a quick multi-inverter installation and commissioning thus reducing the time spent on site.

Fast system integration

Industry standard Modbus (RTU/TCP)/SUNSPEC protocol enables fast system integration.

Two Ethernet ports enable fast and future-proof communication for PV plants.

Protect your assets

Monitoring your assets is made easy, as every inverter is capable to connect to Aurora Vision cloud platform and thanks to the state-of-the-art cybersecurity and Arc Fault Detection option, your assets and profitability are secure in the long term.

Highlights

- Up to 185 kW power rating, highest in class
- All-in-one combiner and fuse free design
- Separate power module and wiring compartment for fast swap and replacement
- Easy access to consumables for fast inspection and replacement
- 12 MPPT and wide input voltage range for maximum energy yield
- WLAN interface for commissioning and configuration
- Remote monitoring and firmware upgrade via the Aurora Vision cloud platform (logger free)
- Free of charge standard access to Aurora Vision cloud



FIMER PVS-175-TL block diagram

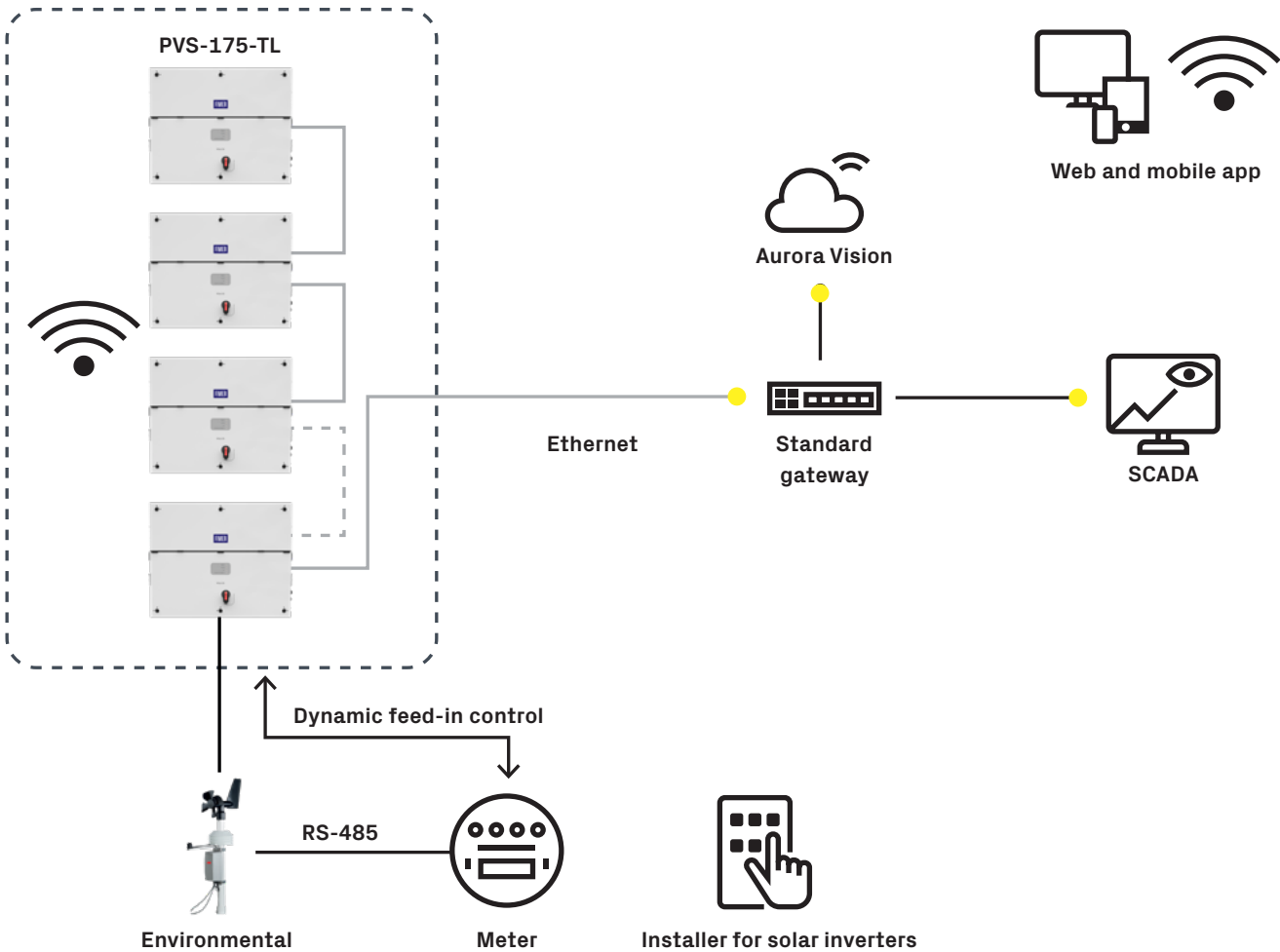

Technical data and types

Type code	PVS-175-TL
Input side	
Absolute maximum DC input voltage ($V_{max,abs}$)	1500 V
Start-up DC input voltage (V_{start})	750 V (650...1000 V)
Operating DC input voltage range ($V_{d,min}...V_{d,max}$)	0.7 x V_{start} ...1500 V (min 600 V)
Rated DC input voltage (V_{dcr})	1100 Vdc
Rated DC input power (P_{dcr})	188000 W @ 30°C - 177000 W @ 40°C
Number of independent MPPT	12
MPPT input DC voltage range ($V_{MPPTmin}...V_{MPPTmax}$) at P_{acr}	850...1350 V
Maximum DC input current for each MPPT ($I_{MPPTmax}$)	22 A
Maximum input short circuit current for each MPPT (I_{SCmax})	30 A
Number of DC input pairs for each MPPT	2 DC inputs per MPPT
DC connection type	PV quick fit connector ¹⁾
Input protection	
DC Series Arc Fault Circuit Interrupter ²⁾	Type I acc. to UL 1699B with single-MPPT sensing capability
Reverse polarity protection	Yes, from limited current source
Input over voltage protection for each MPPT	Type 2 with monitoring
Photovoltaic array isolation control (insulation resistance)	Yes, acc. to IEC 62109-2
Residual Current Monitoring Unit (leakage current protection)	Yes, acc. to IEC 62109-2
DC Load Breaking Disconnect Switch (rating for each MPPT)	20 A/1500 V - 50 A/1000 V
Fuse rating	N/A, No fuses
String current monitoring	MPPT-level current sense
Output side	
AC Grid connection type	Three phase 3W+PE (TN system)
Rated AC power (P_{acr} @ $\cos\phi=1$)	175 000 W @ 40°C
Maximum AC output power ($P_{ac,max}$ @ $\cos\phi=1$)	185 000 W @ $\leq 30^\circ\text{C}$
Maximum apparent power (S_{max})	185 000 VA
Rated AC grid voltage ($V_{ac,r}$)	800 V
AC voltage range	(552...960) ³⁾
Maximum AC output current ($I_{ac,max}$)	135 A
Rated output frequency (f_r)	50 Hz/60 Hz
Output frequency range ($f_{min}...f_{max}$)	45...55 Hz/55...65 Hz ³⁾
Nominal power factor and adjustable range	> 0.995, 0...1 inductive/capacitive with maximum S_{max}
Total current harmonic distortion	< 3%
Max DC current injection (% of I_n)	< 0.5%* I_n
Maximum AC Cable outer diameter / multi core	1 x 53 mm (1 x M63 cable gland)
Maximum AC Cable outer diameter / single core	3 x 32 mm (3 x M40 cable gland)
AC connection type ⁴⁾	Copper Busbar for lug connections with M10 bolts (included)
Output protection	
Anti-islanding protection	According to local standard
Maximum external AC overcurrent protection	200 A
Output overvoltage protection - replaceable surge protection device	Type 2 with monitoring
Operating performance	
Maximum efficiency (η_{max})	98.7%
Weighted efficiency (EURO/CEC)	98.4%
Communication	
Communication interfaces	1xRS485, 2x Ethernet (RJ45) ⁵⁾
Local user interface	4 LEDs, Web User Interface, Mobile APP
Communication protocol	Modbus RTU/TCP (Sunspec compliant)
Commissioning tool	FIMER Installer for solar inverters mobile app/Embedded Web User Interface
Remote monitoring services	Aurora Vision, Plant Portfolio Platform
Advanced features	Built-in Export Limitation control algorithm/Integrated data logging for inverters and accessories / Remote FW update

Technical data and types

Type code	PVS-175-TL
Environmental	
Operating ambient temperature range	-25...+60°C/-13...140°F with derating above 40°C/133 °F
Relative humidity	4%...100% condensing
Sound pressure level, typical	65dB(A) @ 1m
Maximum operating altitude without derating	2000 m / 6560 ft
Physical	
Environmental protection rating	IP 65 (IP54 for cooling section)
Cooling	Forced air
Dimension (H x W x D)	867x1086x419 mm / 34.2"x42.7"x16.5" for, -SX model 867x1086x458 mm / 34.2"x42.7"x18.0" for, -SX2 model
Weight	~76 kg / 167,5 lbs for power module; ~77 kg / 169.7 lbs for Wiring box Overall max ~153 kg / 337.2 lbs
Mounting system	Mounting bracket (vertical support only)
Safety	
Isolation level	Transformerless
Marking	CE
Safety and EMC standard	IEC/EN 62109-1, IEC/EN 62109-2, EN 61000-6-2, EN 61000-6-4, EN 61000-3-11, EN 61000-3-12, EN 301 489-1, EN 301 489-17, EN 300 328, EN 62311,
Grid standard ⁶⁾	CEI 0-16, UTE C 15 712-1, JORDAN IRR-DCC-MV and IRR-TIC, BDEW, VDE-AR-N 4110, VDE-AR-N 4120, P.O. 12.3, DRRG D.4, AS/ NZS4777.2
Available product variants	
Inverter power module	PVS-175-TL-POWER MODULE
24 quick fit connector pairs (2 each MPPT) + DC switches + SPD Type 2 (DC & AC)	WB-SX-PVS-175-TL
24 quick fit connector pairs (2 each MPPT) + DC switches + AC disconnection switch + SPD Type 2 (DC & AC)	WB-SX2-PVS-175-TL
Optional available	
DC Series Arc Fault Circuit Interrupter	Type I acc. to UL 1699B ³⁾ with single-MPPT sensing capability
AC Plate, Single Core Cables	Plate with 4 individual AC cable glands: 3 x M40: Ø 22...32mm, 1 x M32: Ø 18...25mm
AC Plate, Multi Core Cables	Plate with 2 individual AC cable glands: 1 x M63: Ø 37...53mm, 1 x M32: Ø 18...25mm
Pre-Charge ⁷⁾	Night time operation with restart capability
Anti-PID ⁸⁾	Based on night time polarization of the array

- 1) Multicontact MC4-Evo2. Cable couplers may accept up to 10mm² (AWG8)
2) Available as an option. Performance in line with the relevant requirements of the Draft IEC 63027 standard
3) The AC voltage and frequency range may vary depending on specific country grid standard
4) Use of aluminum cables is possible via bi-metallic cable lugs
5) As per IEEE 802.11 b/g/n standard, 2.4 GHz
6) Check your sales channel for availability of the applicable grid standard for your country

- 7) The Inverter cannot verify the photovoltaic array isolation resistance before connection during Night time. When this accessory is present, the inverter must be installed and operate in "restricted areas (access limited to qualified personnel)" according to IEC 62109-2
8) Cannot operate simultaneously with the night mode

Remark. Features not specifically listed in the present data sheet are not included in the product

FIMER Medium Voltage Compact Skid IEC version PVS-175-MVCS

up to 6660 kVA

The FIMER medium voltage compact skid is a plug and play solution designed for large-scale solar power generation using PVS-175 high-power string inverters. It includes the medium voltage transformer, the medium voltage switchgear and all low voltage protections needed to connect the inverters to the transformer.

The PVS-175-MVCS is an integrated product specifically engineered for decentralized solar plants realized with FIMER PVS-175 string inverters. The solution allows to connect up to 36 inverters for a maximum power of 6.7MVA.

The MVCS includes an optimized MV oil-immersed transformer, MV gas-insulated switchgear, all necessary LV protections and connections to attach the solar array and a set of available auxiliary services with independent auxiliary power.

All PVS-175-MVCS components ensure the highest standards of quality, performance and durability.

This medium voltage compact skid is used to connect a PV power plant to a MV electricity grid easily and rapidly. To meet the PV power plant's demanded capacity, several FIMER compact skids can be used and connected in any possible manner thanks to the versatility of the integrated MV switchgear.

The compact skid solution has dimensions suitable for transportation inside a closed 20 feet high cube shipping container. The standardized shipping dimensions ensure cost-effective and safe transportability to the site, even overseas.

The solution's optimized cooling, filtering and high environmental protection degree enable installations in a wide span of ambient conditions, from harsh desert temperatures to cold and humid environments. The FIMER medium voltage compact skid is designed for at least 25 years of operation.

Highlights

- Designed for decentralized systems based on the award-winning 1500 Vdc string inverters PVS-175-TL
- Integrated low voltage distribution panel for a simplified and cost optimized Balance of System (BoS) without the need of additional recombiners
- Quick individual isolation of each feeder, even on-load, for easy and cost-effective maintenance, ensuring maximum uptime
- Individually-protected feeders, enabling separate inverters to be serviced without disrupting the rest of the units connected to the same cluster
- Optimized and very compact layout for integration of all components necessary for medium voltage connection
- Standardized shipping dimensions ensure reduced logistic costs
- Made in Europe product, compatible with most of the world-wide structural regulations and standards
- Vertically integrated product from FIMER, guaranteed by FIMER



Technical data and types

Type code	1850	2220	2590	2960	3330	3700	4070
Inverter	PVS-175-TL						
Number of inverters in parallel	10	12	14	16	18	20	22
Maximum rating in kVA	1850	2220	2590	2960	3300	3700	4070
LV distribution panel							
Number of fused protected feeders	10	12	14	16	18	20	22
Fuse rating of feeders	200 A						
Breakable on load	Yes						
Over voltage protection - replaceable surge arrester	Type 2 (Type 1+2 optional)						
MV transformer							
Transformer type	Oil immersed (ONAN)						
AC Power @ 30° C in kVA	1850	2220	2590	2960	3300	3700	4070
AC Power @ 40° C in kVA	1750	2100	2450	2800	3150	3500	3850
Low voltage level	800 V						
Medium voltage level range	≤ 36kV						
Rated frequency	50 Hz or 60 Hz						
Oil type	Mineral (vegetable optional)						
Tap changer	± 2 x 2.5%						
Winding material (primary / secondary)	Al / Al						
Eco efficiency optional	Yes						
MV switchgear							
Switchgear type	SF ₆ -insulated						
Rated current	630 A						
Configuration	Single (CV) or double feeder (CCV)						
Protection (up to 24 kV / up to 36 kV)	Circuit breaker (16 kA or 20 kA / 20 kA or 25 kA)						
Protection relay type	REJ603 (others on request)						
Motorized optional	Yes						
Auxiliary supply							
Auxiliary transformer power	10 kVA (higher on request)						
Auxiliary transformer voltage	800 / 400-230 V						
Low voltage distribution panel for auxiliary functions	Yes						
Mechanical characteristics							
Dimensions (length x width x height) in mm	5700 x 2150 x 2500						
Weight approx. in ton	9	9	10	10	10	11	11
Environmental							
Operating temperature range	-25° C ... +60° C (with derating above 40° C)						
Operating altitude range	≤ 2000 m						
Relative humidity (non-condensing)	≤ 95%						
Environmental protection rating	IP 54						
Painting corrosion protection	C4 (C5M optional)						
Product compliance							
Conformity	IEC 60364, IEC 61936-1, IEC 60502-1						

Technical data and types

Type code	4440	4810	5180	5550	5920	6290	6660
Inverter	PVS-175-TL						
Number of inverters in parallel	24	26	28	30	32	34	36
Maximum rating in kVA	4440	4810	5180	5550	5920	6290	6660
LV distribution panel							
Number of fused protected feeders	24	26	28	30	32	34	36
Fuse rating of feeders	200 A						
Breakable on load	Yes						
Over voltage protection - replaceable surge arrester	Type 2 (Type 1+2 optional)						
MV transformer							
Transformer type	Oil immersed (ONAN)						
AC Power @ 30° C in kVA	4440	4810	5180	5550	5920	6290	6660
AC Power @ 40° C in kVA	4200	4550	4900	5250	5600	5950	6300
Low voltage level	800 V						
Medium voltage level range	≤ 36kV						
Rated frequency	50 Hz or 60 Hz						
Oil type	Mineral (vegetable optional)						
Tap changer	± 2 x 2.5%						
Winding material (primary / secondary)	Al / Al						
Eco efficiency optional	Yes						
MV switchgear							
Switchgear type	SF ₆ -insulated						
Rated current	630 A						
Configuration	Single (CV) or double feeder (CCV)						
Protection (up to 24 kV / up to 36 kV)	Circuit breaker (16 kA or 20 kA / 20 kA or 25 kA)						
Protection relay type	REJ603 (others on request)						
Motorized optional	Yes						
Auxiliary supply							
Auxiliary transformer power	10 kVA (higher on request)						
Auxiliary transformer voltage	800 / 400-230 V						
Low voltage distribution panel for auxiliary functions	Yes						
Mechanical characteristics							
Dimensions (length x width x height) in mm	5700 x 2150 x 2500						
Weight approx. in ton	12	12	13	13	14	14	15
Environmental							
Operating temperature range	-25° C ... +60° C (with derating above 40° C)						
Operating altitude range	≤ 2000 m						
Relative humidity (non-condensing)	≤ 95%						
Environmental protection rating	IP 54						
Painting corrosion protection	C4 (C5M optional)						
Product compliance							
Conformity	IEC 60364, IEC 61936-1, IEC 60502-1						

FIMER Medium Voltage Compact Skid for US market PVS-175-MVCS up to 5920 kVA

The FIMER medium voltage compact skid is a plug and play solution designed for large-scale solar power generation using PVS-175 high-power string inverters. It includes the medium voltage transformer, integrated medium voltage switch, and all low voltage protections needed to connect the inverters to the transformer.

The PVS-175-MVCS is an integrated product specifically engineered for decentralized solar plants realized with FIMER PVS-175 string inverters.

All PVS-175-MVCS components ensure the highest standards of quality, performance and durability.

This medium voltage compact skid is used to connect a PV power plant to a MV electricity grid easily and rapidly. To meet the PV power plant's demanded capacity, several FIMER compact skids can be used and connected in any possible manner thanks to the versatility of the integrated MV switchgear.

The solution's optimized cooling, filtering and high environmental protection degree enable installations in a wide span of ambient conditions, from harsh desert temperatures to cold and humid environments. The FIMER medium voltage compact skid is designed for at least 25 years of operation.

Highlights

- Designed for decentralized systems based on the award-winning PVS-166/175-TL 1500 Vdc string inverters
- Quick individual isolation of each feeder, even on-load, for easy and cost-effective maintenance, ensuring maximum uptime
- Individually-protected feeders, enabling separate inverters to be serviced without disrupting the rest of the units connected to the same cluster
- Optimized and very compact layout for integration of all components necessary for medium voltage connection
- Standardized shipping dimensions ensure reduced logistic costs



String inverter

PVS-350-TL

350 kW

The new PVS-350-TL by FIMER is designed to satisfy the growing demand of multi-MPPT string inverters for utility PV systems, offering record-high AC capacity combined with a DC front-end optimized for the latest PV modules to maximize the ROI of ground mounted systems based on a decentralized architecture.



High power density

This new multi-MPPT string inverter with a record-high capacity and power-to-weight ratio exceeding 3kW/kg, delivers up to 350 kVA at 800 Vac. This does not only reduce the logistics and installation costs but also the Electrical Balance of System costs for free field utility-scale ground mounted PV installations. MV stations of up to 15% higher capacity can be combined with PVS-350, increasing the single power block capacity and reducing the overall number of stations per MWac of installed power.

Future-proof Multi-MPPT 1500 Vdc platform

The inverter comes equipped with 12 MPPTs, each rated 45A Imp and 60A Isc. The MPPT design has been specifically optimized for the connection of 2 strings of the latest ultra-high power PV modules based on M10 (182x182mm) and G12 (210x210mm) cells. The DC/AC ratio can be optimized to fully exploit the benefits of this new module formats while offering maximum system yields ($\eta_{max} > 99\%$), enabling additional cost savings on trackers compared to traditional 166mm modules.

Installer friendly design

Quick and easy installation, the existing PV module's mounting systems can be used to install the inverters, thus saving time and costs on site preparation and hire of plant. The fuse and combiner free design avoids the need for external components, such as separate DC combiner boxes and AC first level combiners. This is also possible thanks to the integrated DC disconnect switch and to the segregated AC wiring compartment supporting both Al and Cu cables up to 400mm².

Protect and maximize the efficiency of your assets

Supported by the Aurora Vision cloud platform, the healthy status of the whole PV array can be controlled online through the single string-level I-V curve analysis performed on each inverter. This advanced diagnostic services can be combined with the integrated Arc Fault Detection and PID recovery options, ensuring assets' durability and the profitability of the PV system.

FIMER Digital Platform combining Cloud and Edge Technologies
The cloud and edge computing capabilities, big data analytics

and FIMER's digital platform can help the customer to solve the challenge of the new digital era.

The FIMER Digital Platform consists of ICT technologies and a full set of functionalities and services properly combined at both cloud and edge level, able to provide the customer with a fully integrated future proof solution characterized by higher performance, higher reliability, maximized cyber security and always aligned with needs and expectations in terms of minimizing Total Cost of Ownership and facilitating maintenance activities in large scale distributed solar generators.

The new FIMER PVS-350 inverter integrates the last standard IP-based technology; in addition, through the integration of an advanced smart cluster-level aggregator gateway many more functionalities and services can be enabled at plant level such as a fully scalable hierarchical plant controlling solution, effective integration with any 3rd party PPC or SCADA system and always according to any modern regulatory norms and grid operators standard (like IEC 61850, IEC 104, etc...).

Additional premium services are also available to exploit the smart functionalities integrated in each unit (including DC string diagnosis, prognostic and predictive maintenance, scheduled FW upgrade and remote parameter setting and many others), allowing the system to easily meet the most demanding grid support requirements for systems of any size, as well as enabling both owner and aggregator to play the new solar game in the digital era.

Highlights

- The most powerful string inverter in Utility (350 kVA); Power to weight ratio > 3kW/kg
- 12 MPPT/45A – Optimized for the latest generation Ultra-High power PV modules (182mm & 210mm)
- Maximum Energy Yield, $\eta_{max} > 99\%$
- String diagnosis through online IV curve analysis
- Fuse-free design
- Remote firmware upgrade and Multi inverter commissioning
- Segregated AC wiring compartment, support both Al and Cu Cable up to 400mm²
- DC Series Arc Fault Circuit Interrupter
- PID recovery function (optional)
- Support Q@night function

Technical data and types

Type code	PVS-350-TL
Input side	
Absolute maximum DC input voltage ($V_{max,abs}$)	1500 V
Start-up DC input voltage (V_{start})	600...1000 V
Operating DC input voltage range ($V_{dcmin}...V_{dcmax}$)	0.7 x V_{start} ...1500 V (min 500 V)
Rated DC input voltage (V_{dcr})	1080 V
Number of independent MPPT	12
Maximum DC input current for each MPPT ($I_{MPPT,max}$)	45 A
Maximum input short circuit current for each MPPT	60 A
Number of DC inputs pairs for each MPPT	2
DC connection type	MC4-Evo2
Input protection	
DC Series Arc Fault Circuit Interrupter	Standard
Reverse polarity protection	Yes, from limited current source
Input over voltage protection for each MPPT - Type 2 surge arrester	Yes, with monitoring
Input over voltage protection for each MPPT - Type 1+2 surge arrester	Optional, with monitoring
Photovoltaic array isolation control (Insulation Resistance)	Yes, acc. to IEC 62109-2
Residual Current Monitoring Unit (leakage current protection)	Yes, acc. to IEC 62109-2
DC switch	Yes
String current monitoring	Yes
Output side	
AC grid connection type	Three phase 3W+PE
Rated AC power ($P_{ac,r}$)	333000 W
Maximum AC output power ($P_{ac,max} @ \cos\phi=1$)	350000 W
Maximum apparent power (S_{max})	350000 VA
Rated AC grid voltage ($V_{ac,r}$)	800 V
Rated AC output current ($I_{ac,max}$)	240.3 A
Maximum AC output current ($I_{ac,max}$)	253 A
Rated output frequency (f)	50 Hz / 60 Hz
Nominal power factor and adjustable range	> 0.995, 0.8 inductive/capacitive with maximum S_{max}
Total current harmonic distortion	< 3%
Max DC Current Injection (% of I_n)	< 0.5% I_n
Maximum AC Cable / single core (multi core)	4x1x400mm ² (4x300mm ²)
AC connection type	Type Terminal block M12 cable lug
Output protection	
Anti-islanding protection	According to local standard
Output overvoltage protection - Type 2 surge protection device	Yes, with monitoring
Operating performance	
Maximum efficiency (η_{max})	≥99.02 %
Weighted efficiency (EURO)	≥98.85 %
Communication	
Communication interface	Ethernet, RS-485
Local user interface	4 LEDs, Web User Interface, Mobile APP
Communication protocol	Modbus RTU/TCP (Sunspec compliant)
Commissioning tool	Web User Interface / Mobile APP
Monitoring	Plant Portfolio Platform
FW update	locally/remotely
Parameter upgrade	interface locally/remotely
Environmental	
Operating ambient temperature range	-25...+60°C
Relative humidity	4%...100% condensing
Maximum operating altitude	4000 m

Technical data and types

Type code	PVS-350-TL
Physical	
Environmental protection rating	IP 66
Cooling	Forced air cooling
Dimension (H x W x D)	740 x 1100 x 490 mm
Weight	≤110kg
Safety	
Isolation level	Transformerless
Marking	CE
Safety and EMC standard (planned)	IEC/EN 62109-1, IEC/EN 62109-2, EN 61000-6-2, EN 61000-6-4, EN55011:2017
Optional available	
Online IV curve analysis	Optional
Q@night	Optional
PID Recovery	Optional

Notes:

- 1) External AC protection is mandatory

String inverter Medium Voltage Modular Compact Skid PVS-260/300-MVMCS

6300 to 7200 kW

The new FIMER medium voltage modular compact skid is a plug&play solution designed to seamlessly and efficiently replace monolithic converter solutions on large-scale solar power generation systems based on a centralized architecture. Combining up to 24 single MPPT power conversion modules in a fully-equipped factory pre-assembled and pretested 40 feet HC MV station, the new platform can compete with multi-MW scale station designs of the latest central inverters, allowing system designers to apply the modular architecture to systems of any kind and any size.



Centralized System Architecture / Modular Conversion Core

The PVS-260/300-MVMCS is an integrated product specifically engineered for utility-scale PV systems adopting a centralized system architecture.

The PVS-260/300-MVMCS is modular in nature. Indeed, the system includes up to 24 single MPPT independent PVS-260/300 power conversion modules, arranged in a fully-equipped factory pre-assembled and pretested 40 feet HC MV station with a total MVA capacity as high as 7200 kVA. Designed to seamlessly and efficiently replace monolithic converter solutions on large-scale solar power generation systems, this solution outperforms any conventional central system, allowing PV designers to extend the benefits of modular conversion to systems of any kind and any size.

The benefits of Modular Conversion: lower LCOE

The PVS-260/PVS-300-MVMCS by FIMER makes it possible to align the capital costs of a modular solution with those of a centralized system, while ensuring the following benefits that are typical of a modular conversion solution:

- Higher system availability, above 99.9% compared to 99.5% maximum from central solutions, thanks to the inherent fault tolerance and reduced MTTR guaranteed by modular conversion.
- Lower O&M efforts thanks to the granularity of power conversion accomplished with smaller and swappable power blocks. Depending on site-specific conditions this achieves a remarkable 1.5 to 2.5 percent reduction on the LCOE of a modular conversion architecture compared to a central solution. Moreover, all power electronics is concentrated nearby the other critical AC power assets to simplify the control and routine maintenance.

Fully equipped and engineered by FIMER

The solution's optimized cooling, filtering and high environmental protection degree allow its installation in a wide span of environmental conditions, from harsh desert temperatures to cold and humid environments.

The MVMCS includes an optimized MV oil-immersed transformer, MV gas-insulated switchgear, all necessary LV protections and connections to the (up to) 24 conversion modules and a set of available auxiliary services with independent auxiliary power. Depending on the number of conversion modules, the MVMCS provides up to 24 independent MPPTs and direct connection to the up to 24 individual DC cable pairs coming from the DC recombiner boxes. All components are part of the FIMER portfolio, ensuring the highest standards of quality, performance and durability.

Unmatched flexibility and scalability

Thanks to its inherent granularity, the MVMCS provides an un-matched scalability to adapt to systems of any size, any type. This medium voltage compact skid is used to connect a PV power plant to a MV electricity grid easily and rapidly. To meet the PV power plant's demanded capacity, several FIMER compact skids can be used and connected thanks to the versatility of the integrated MV switchgear.

Reduced logistic costs

The compact skid solution is suitable for transportation inside a closed 40 feet high cube shipping container. The standardized shipping dimensions ensure cost-effective and safe transportability to the site, even overseas.

Highlights

- Designed for centralized systems based on up to 24 units of the record-high power capacity (260/300 kVA) and power density 1500 Vdc single-MPPT conversion modules PVS-260/300.
- Integrated low voltage distribution panel for a simplified and cost optimized Balance of System (BoS) without the need for any additional recombiners.
- Quick individual isolation of each conversion module, even on-load, for easy and cost-effective maintenance, ensuring maximum uptime.
- Individually-protected feeders, enabling separate inverters to be serviced without disrupting the rest of the units connected to the same cluster.
- DC connection cabinet for up to 24 individual DC home runs (support 400mm² Al cable).
- Optimized and very compact layout for integration of all components necessary for medium voltage connection.
- Standardized shipping dimensions ensure reduced logistic costs.
- Made in Europe product, compatible with most of the world-wide structural regulations and standards.
- Vertically integrated product manufactured by FIMER, guaranteed by FIMER.

Technical data and types

Maximum rating in KVA	Up to 6300	Up to 7200
Inverter		
Inverter module	PVS-260-TL	PVS-300-TL
Number of inverter modules		Up to 24
Number of independent MPPT		Up to 24
Absolute maximum DC input voltage ($V_{max,abs}$)		1500 V
Operating DC input voltage range ($V_{dcmin}...V_{dcmax}$)	850...1500 V	978...1500 V
Maximum DC input current for each MPPT ($I_{MPPTmax}$)		325 A
Maximum input short circuit current for each MPPT		700 A
Number of DC inputs pairs for each MPPT		2
DC connection type	Type Terminal block M12 cable lug up to 400mm ²	
AC output voltage	600 V	690 V
LV distribution panel		
Number of fused protected feeders		Up to 24
Fuse rating of feeders		350 A
Breakable on load		Yes
Over voltage protection – Type 2 replaceable surge arrester		Yes, with monitoring
Over voltage protection – Type 1+2 replaceable surge arrester		Optional, with monitoring
MV Transformer		
Transformer type	Sealed oil immersed (ONAN)	
Maximum AC power	Up to 6300 kVA	Up to 7200 kVA
Rated Low voltage level	600 V	690 V
Rated Medium voltage level		≤ 36 kV
Rated frequency		50 Hz / 60 Hz
Oil type	Mineral (Vegetable as an option)	
Tap changer		± 2 x 2.5%
Windings material (primary / secondary)		Al / Al
ECO efficiency		Optional
MV switchgear		
Switchgear type	SF6 - Insulated	
Rated current	630 A	
Configuration	Single feeder (CV) or double feeder (CCV)	
Protection (up to 24 kV / up to 36 kV)	Circuit Breaker (16 kA or 20 kA / 20 kA or 25 kA)	
Protection relay	ABB REJ603 or equivalent (others on request)	
Motorization	Optional	
Auxiliary supply		
Auxiliary supply transformer power	10 kVA (higher on request)	
Auxiliary transformer voltage	600 V / 400-230 V	690 V / 400-230 V
Low voltage distribution panel for auxiliary functions	Yes	
Mechanical characteristics		
Dimensions (length x width x height) in mm	11400 x 2150 x 2500	
Environmental		
Operating ambient temperature range	-25...+60° C	
Operating altitude range	≤ 2000 m	
Relative humidity (non -condensing)	≤ 95%	
Environmental protection rating	IP 54 (IP66 for inverters)	
Painting corrosion protection	C4 (C5M optional)	
Product compliance		
Conformity	IEC 60364, IEC 61936-1, IEC 60502-1	

String inverter

PVS-260/300-TL

262,5 to 300 kW

The new PVS-260/300-TL is the innovative single-MPPT converter by FIMER that forms the basic building block of a new generation of modular converter solutions for utility PV systems, offering record-high AC capacity and power-to-weight ratio to enable the integration of utility-scale ground mounted PV systems based on a centralized modular architecture.



High power density

This new single-MPPT string inverter with a record-high capacity and power-to-weight ratio exceeding 3kW/kg, delivers up to 300 kVA (260 kVA) at 690 Vac (600 Vac). This not only reduces the logistics and installation costs but also the Electrical Balance of System costs for free field utility-scale ground mounted PV installations. MV stations of up to 7200 KVA capacity can be combined with 24 units of PVS-300, increasing the single power block to reach the same capacity of the latest central monolithic solutions within the same physical size, providing all the benefits of a modular conversion at an equivalent initial cost.

Reduced O&M cost

The granularity of the power conversion is accomplished with smaller capacity and swappable power blocks that ensure minimal MTTR and reduced labor cost compared to the on-site repairs of central inverter solutions.

Maximum Energy Yield

With a maximum efficiency exceeding 99% and weighted efficiency above 98.8%, the PVS-260/300-TL is on the leading edge of the power conversion technology applied to PV systems, offering the maximum energy yield to utility-scale systems of any size.

This is combined with the highest availability exceeding 99.9% compared to 99.5% maximum from monolithic MW-scale inverters, thanks to the inherent fault tolerance, reduced MTTR and easy/low labor cost guaranteed by the swappable modular converters which further contributes to preserve the optimal system yield and maximum ROI.

Protect and maximize the efficiency of your assets

Advanced inverter diagnostic and prognostic services can be combined with PID recovery options, ensuring your assets and profitability are secured throughout the entire PV system operating life.

FIMER Digital Platform

Thanks to cloud and edge computing capabilities, big data analytics and AI the FIMER digital platform can help customers to solve the challenge of the new digital era.

The FIMER Digital Platform consists of ICT technologies and a full set of functionalities and services properly combined at both cloud and edge level able to provide customers with a fully integrated future-proof solution characterized by higher performance, higher reliability, maximized cyber security and always aligned with needs and expectations in terms of minimizing Total Cost of Ownership and facilitating maintenance activities in large scale distributed solar generators.

The new FIMER PVS-260/300 inverter integrates the last standard IP-based technology; in addition, through the integration of an advanced smart cluster-level aggregator gateway, many more functionalities and services can be enabled at plant level such as a fully scalable hierarchical plant controlling solution, effective integration with any 3rd party PPC or SCADA system and always according to any modern regulatory norm and grid operator standard (like IEC 61850, IEC 104, etc...).

Additional premium services are also available to exploit the smart functionalities integrated in each unit (including diagnosis, prognostic and predictive maintenance, scheduled FW upgrade and remote parameter's setting and many others), allowing the system to easily meet the most demanding grid support requirements for systems of any size, as well as to enable both owner and aggregator to play the new solar game in the digital era.

Highlights

- The most powerful single-MPPT string inverter in Utility (300 kVA); Power to weight ratio > 3kW/kg
- Optimized for the integration of Utility PV systems based on centralized architecture with modular converters
- Maximum Energy Yield, $\eta_{MAX} > 99\%$
- Remote firmware upgrade and Multi inverter commissioning
- Segregated DC & AC wiring compartment, support both Al and Cu Cable up to 400mm²
- PID recovery function (optional)
- Support Q@night function

Technical data and types

Type code	PVS-260-TL	PVS-300-TL
Input side		
Absolute maximum DC input voltage ($V_{max,abs}$)		1500 V
Operating DC input voltage range ($V_{dc,min}...V_{dc,max}$)	850...1500 V	978...1500 V
Number of independent MPPT		1
Maximum DC input current ($I_{MPP,Tmax}$)		325 A
Maximum input short circuit current		700 A
Number of DC inputs pairs		2
DC connection type	Type Terminal block M12 cable lug up to 400mm ²	
Input protection		
Reverse polarity protection	Yes, from limited current source	
Input over voltage protection - Type 2 surge arrester	Yes, with monitoring	
Input over voltage protection - Type 1+2 surge arrester	Optional, with monitoring	
Photovoltaic array isolation control (Insulation Resistance)	Yes, acc. to IEC 62109-2	
Residual Current Monitoring Unit (leakage current protection)	Yes, acc. to IEC 62109-2	
Output side		
AC Grid connection type	Three phase 3W+PE	
Rated AC power ($P_{ac,r}$)	238700 W	273000 W
Maximum AC output power ($P_{ac,max} @ \cos\phi=1$)	262500 W	300000 W
Maximum apparent power (S_{max})	262500 VA	300000 VA
Rated AC grid voltage ($V_{ac,r}$)	600 V	690 V
Rated AC output current ($I_{ac,max}$)	229.7 A	228.5A
Maximum AC output current ($I_{ac,max}$)		253 A
Rated output frequency (f_r)	50 Hz / 60 Hz	
Nominal power factor and adjustable range	> 0.995, 0.8 inductive/capacitive with maximum S_{max}	
Total current harmonic distortion	< 3%	
Max DC Current Injection (% of I_n)	< 0.5%* I_n	
Maximum AC Cable / single core (multi core)	4x1x400mm ² (4x300mm ²)	
AC connection type	Type Terminal block M12 cable lug	
Output protection		
Anti-islanding protection	According to local standard	
Output overvoltage protection - Type 2 surge protection device	Yes, with monitoring	
Operating performance		
Maximum efficiency (η_{max})	≥99.02	
Weighted efficiency (EURO/CEC)	≥98.85	
Communication		
Communication interface	Ethernet, RS-485	
Local user interface	4 LEDs, Web User Interface, Mobile APP	
Communication protocol	Modbus RTU/TCP (Sunspec compliant)	
Commissioning tool	Web User Interface / Mobile APP	
Monitoring	Plant Portfolio Platform	
FW update	locally/remotely	
Parameter upgrade	locally/remotely	
Environmental		
Operating ambient temperature range	-25...+60°C	
Relative humidity	4%...100% condensing	
Maximum operating altitude	4000 m	
Physical		
Environmental protection rating	IP 66	
Cooling	Forced air cooling	
Dimension (H x W x D)	700 x 950 x 450 mm	
Weight	≤100kg	
Safety		
Isolation level	Transformerless	
Marking	CE	
Safety and EMC standard (planned)	IEC/EN 62109-1, IEC/EN 62109-2, EN 61000-6-2, EN 61000-6-4, EN55011:2017	
Grid standard (check your sales channel for availability)	TBC	
Option available		
Q@night	Optional	
PID Recovery	Optional	

**With the new PVS-350
and PVS-260/300,
FIMER offers the best
solutions for both
decentralized and
centralized applications,
covering 100% of
Utility-scale needs**



PVS string inverters

digital capabilities

FIMER PVS string inverters comes with all the digital capabilities and functionalities enabled by the new FIMER digital communication platform allowing great advantages in terms of smart grid integration and controlling as well as reducing time spent on site..

“All-in-one” solution

The digital technologies of the string inverters allow the electric grid to better adapt to the dynamic behavior of renewable energy and distributed generation, helping both consumers and utilities to access these resources and harvest their benefits from remote. The string inverters features natively the proven standard TCP/IP technology and the open and widely used Modbus RTU and TCP Sunspec allowing customer to easy integrate the inverter with any modern systems in range of IoT and in compliance with modern regulatory norms worldwide.

The integrated data logging capabilities, the direct transferring of telemetry data to the cloud via Internet and the innovative built-in distributed control algorithm allow

meeting any limit to the plant exported power at the point of connection. There is no need of using any additional device beyond the inverter which ensures maximum flexibility in plant designing and reduces the complexity of the plant dramatically. Consequently, it increases the PV plant's reliability.

Highlights

- Protecting customer's investment
- Reduced plant complexity and increased reliability
- Minimum TCO
- Improved user experience
- Support to cross-sector integration
- IoT ready

Monitoring and control solutions



Aurora Vision®

Aurora Vision® is a scalable, secure and reliable cloud-based platform that allows customers to remotely manage and analyze the main key performance indicators of their solar power plants as well as use advanced diagnostics tools, in all market segments. This cloud-based solution, accessible through an Aurora Vision® account, is structured to offer multiple services and products all designed with specific customer needs in mind:

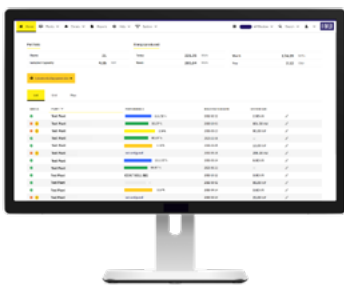

Plant Portfolio Manager

An advanced professional webportal that allows stakeholders (such as installers/ operators/ managers) to monitor and control fleets of photovoltaic systems installed for final customers.



Energy Viewer

A smart and easy-to-use mobile app for monitoring the main power generation and self-performances indicators, for owners of residential and commercial PV plants, in order to keep energy use and savings in check.

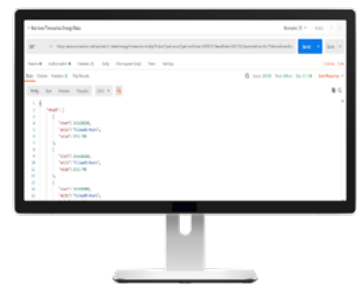

Aurora Vision® APIs

Harness the power of data from FIMER's photovoltaic systems to design solutions and provide opportunities.

Monitoring to improve your productivity

Real-time data acquisition, early fault detection and Email alerting are some of the key features that will help to optimize the average repair time of a solar system.

Thanks to the granularity of the string-level monitoring and intelligent fault descriptions, detailed analyses can be extrapolated that lead to the type of repair needed by also determining the potential spare parts to be used, thus minimizing inconclusive interventions.

With the availability of professional diagnostic tools such as Plant Performance and Assets Diagnostic charts that have been carefully designed, combined with comprehensive asset management and the ability to perform remote firmware upgrades, it is easy to positively impact maintenance operations thus optimizing costs and providing great benefits in terms of customer satisfaction.

Finally, thanks to the administration tools, solar professionals can administer an entire portfolio of solar plants by managing both the lifecycle of solar assets and the accounts of employees and customers.

Versatility to achieve energy independence

Aurora Vision's versatility and cross-integration allows homeowners to benefit directly from the platform, simply by choosing to self-register their PV system or by having their solar power plant registration handled directly by their trustworthy installer.

Everything is easily accessible through iOS and/or Android systems (both tablets and smartphones) without the need to install any additional software or perform data back-ups; by leveraging the power of FIMER inverter data everything is managed through the Aurora Vision® cloud-based platform. The products provided are designed with modular and easy-to-use dashboards, offering all the main data at your fingertips.

Users can therefore start to optimize their own self-performances, leading to have a clear assessment of all energy flows and household consumption.

Export limitation solution

The new generation of FIMER PVS-string inverters is even more smart thanks to the innovative built-in distributed control algorithm which allows meeting export limits without the need of installing any additional system or device*.

The new innovative FIMER Export limitation solution allows solar plant owners to get the maximum energy from their inverters, without needing to invest in additional external systems, and is compliant with the export limits set by grid operators and utilities worldwide. It is the only IP based solution currently on the market** that does not require the installation of any additional components besides PVS series string inverters and a supported and standard modbus meter, allowing for great advantage in terms of both investments and ownership costs, plant reliability and system complexity.

All PVS series string inverters come with an innovative distributed control algorithm built-in which, once quickly configured through the Installer for solar inverters app set-up wizard, allows the entire plant to dynamically follow the load curves in compliance with the most restrictive regularity norms worldwide.

To get the solution properly configured and working, the supported standard meter needs to be installed at the point of connection and paired to the inverters just once, by either direct RS-485 serial line, to the inverter's serial port, or over

Ethernet (Local Area Network).

According to the specific meter installed, the new FIMER export limitation algorithm can work indistinctly in small commercial installations, with just a few inverters connected to the low voltage stage, as well as in a large commercial/utility-scale plants, where up to maximum 15 units (a higher number of units may be authorized upon request) per plant are connected to the grid by middle voltage stage.

Highlights

- IP based solution
- Distributed control algorithm built-in the inverter just standard meter needed and no external controller required
- PVS string inverters supported (15 units per plant)
- Just a standard Modbus meter (either RS-485 or Ethernet) needed
- System setting through the Installer for solar inverters mobile app
- Fully integrated with Aurora Vision cloud
- Control can be activated on both low and medium point of connection
- High performance control solution
- Compliant with modern regulatory norms worldwide (such as: AS/NZS 4777.2:2015, G100, Thailand MEA)
- Failsafe mechanism allow to respect of the limit set at the energy exported to grid even in case of fault occurred to the inverter or meter

* With the exception of a standard Modbus meter from the ones supported.

** To date

*** 40 units achievable on request

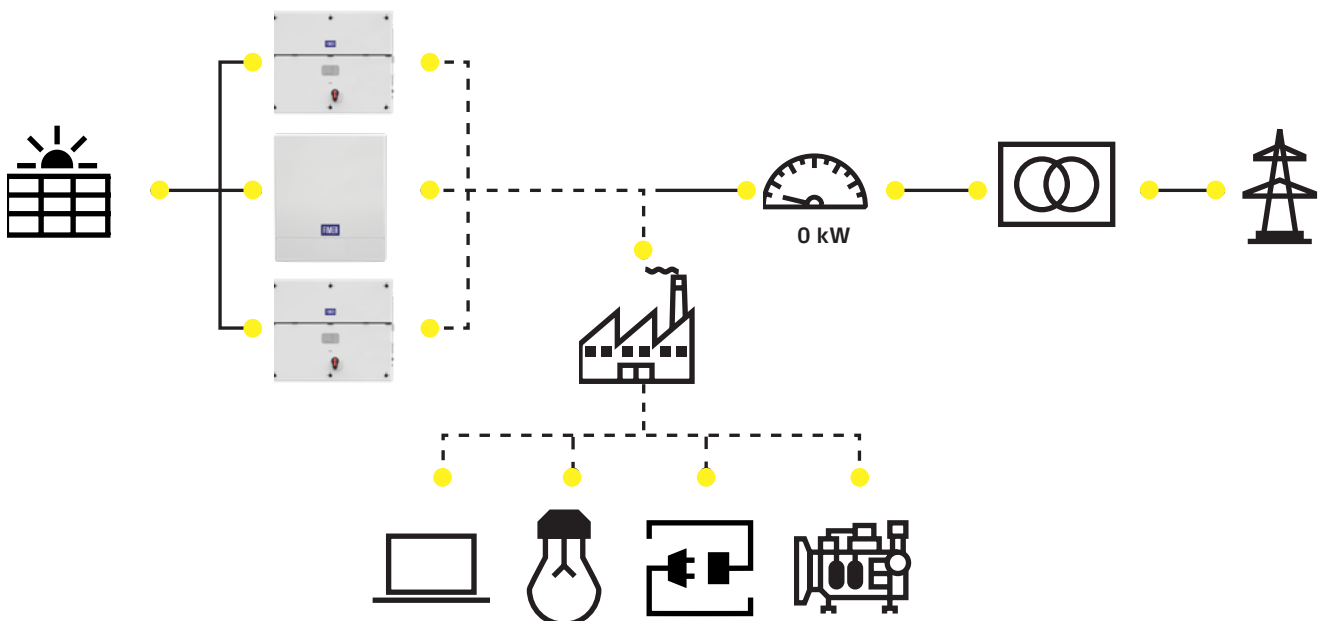

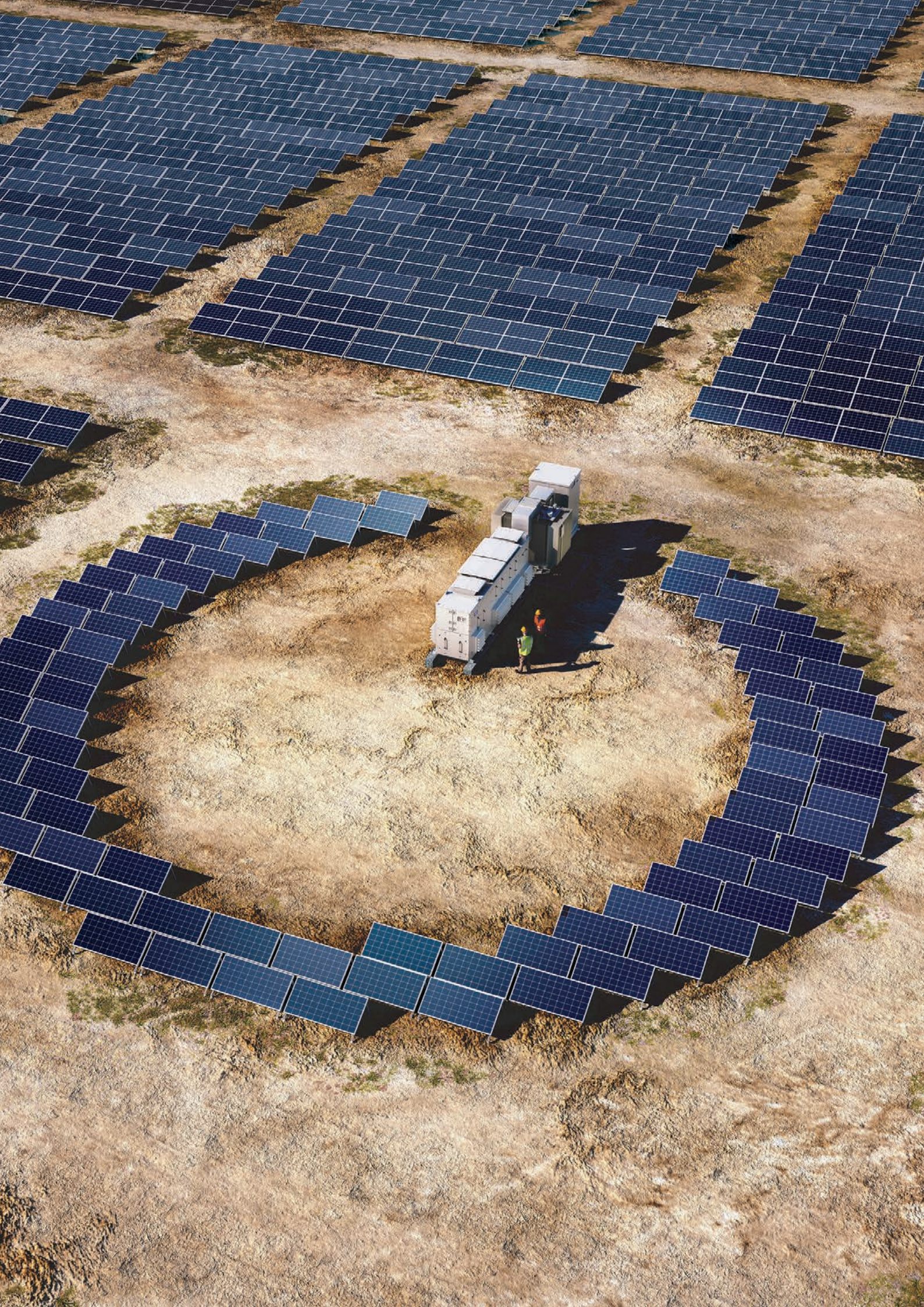

FIMER central inverter solutions

FIMER's offering includes highly cost-effective and performant central inverters as well as complete plug and play stations with inverters and medium voltage (MV) components for an attractive return on investment.

Central inverters for maximized total efficiency

FIMER's central inverter portfolio is based on decades of experience with power converting technology, which has been custom adapted for the PV business.

This ensures that the product itself, and the processes to support it over the plant lifetime, are optimized and offer a truly bankable solution.

The central inverter's industrial design and modularity combined with FIMER's life cycle service approach simplify the operation of the inverters. This assures maximum uptime of the plant and highest return on your investment.

The high efficiency, together with high reliability and extremely low auxiliary power consumption give investors maximized total efficiency over the lifetime of the plant

Highlights

- Power ratings up to 5000 kVA
- 1000 V and 1500 Vdc input voltage
- All-in-one design approach to reduce the amount of external components needed

Central inverter solutions for high performance

FIMER's central inverter solutions are designed for large multi-megawatt PV power plants and are most cost-effective by feeding electricity directly to the to the MV grid.

The components' compatibility ensures highest standards of quality, performance and durability.

The complete plug and play stations are available in different designs, to provide the most feasible solutions for every weather and site condition.

Highlights

- Plug and play solutions with ratings up to 5000 kVA
- Customized solutions with ratings up to 10000 kVA
- Standardized shipping dimensions to ensure cost-effective and safe transportability



FIMER central inverter (1500 Vdc) PVS980-58

up to 5000 kVA

The new high power FIMER central inverters raise the performance, cost efficiency and ease of installation to new levels. The inverters are aimed at system integrators and end users who require high-performance solar inverters for large photovoltaic (PV) power plants, and are optimized for multi-megawatt power plants.

World's leading inverter platform

Like other FIMER central inverters, the PVS980-58 has been developed on the basis of decades of experience in the industry and proven technology platform. Unrivalled expertise from the world's market and technology leader in frequency converters is the hallmark of this solar inverter series.

The PVS980-58 inverter is one of the most efficient and cost-effective ways of converting the direct current (DC) generated by solar modules into high quality and CO₂-free alternating current (AC) that can be fed into the power distribution network.

PVS980-58 central inverters from FIMER

FIMER PVS980-58 central inverters are ideal for large PV power plants. The high DC input voltage, high efficiency, proven components, compact and modular design and a host of life cycle services ensure FIMER PVS980-58 central inverters provide a rapid return on investment. New extended power range along with fast site installation raises the total cost efficiency to a new level.

Highlights

- High total performance
- Modular product design
- High DC input voltage up to 1500 VDC
- Extensive DC and AC side protection
- Easy to commission, no separate chiller installation
- Fast and easy AC coupling to transformer by busbars
- Versatile design for large-scale PV plants to minimize system costs
- Complete range of industrial data communication options including remote monitoring
- Life cycle service and support through FIMER's extensive global service network



Technical data and types

Product Type designation, PVS980-58	PVS980-58 4.3 MVA -4348kVA-I	PVS980-58 4.6 MVA -4565kVA-J	PVS980-58 4.8 MVA -4782kVA-K	PVS980-58 5.0 MVA -5000kVA-L
Input (DC)				
Maximum recommended input power (PPV,max) ¹⁾	8696 kWp	9130 kWp	9564 kWp	10000 kWp
Maximum DC short circuit current	16 kA			
Maximum operational DC current	5300 A			
Maximum operational DC voltage (U _{max} (DC)) ²⁾	1500 V			
DC voltage range for maximum power (U _{dc, mpp}) @ -20 to +25 °C	850 to 1350 V	893 to 1350 V	935 to 1350 V	978 to 1350 V
DC voltage range for maximum power (U _{dc, mpp}) @ 35 °C	850 to 1250 V	893 to 1250 V	935 to 1250 V	978 to 1250 V
DC voltage range for maximum power (U _{dc, mpp}) @ 50 °C	850 to 1100 V	893 to 1100 V	935 to 1100 V	978 to 1100 V
Number of MPPT trackers	1			
Number of protected DC inputs ³⁾	20-36 (+/-)			
Output (AC)				
Power @ 25 °C	4348 kVA	4565 kVA	4782 kVA	5000 kVA
AC current @ 25 °C	4184 A			
Power @ 35 °C	4229 kVA	4441 kVA	4652 kVA	4864 kVA
AC current @ 35 °C	4070 A			
Power (S _{N(AC)}) @ 50 °C	3845 kVA	4037 kVA	4229 kVA	4421 kVA
AC current (I _{N(AC)}) @ 50 °C	3700 A			
Nominal output voltage (U _{N(AC)}) ⁴⁾	600 V	630 V	660 V	690 V
Output frequency ⁵⁾	50/60 Hz			
Harmonic distortion, current ⁶⁾	< 3%			
Maximum AC short circuit current from network	80 kA (1 s RMS)			
Distribution network type ⁷⁾	TN and IT			
Efficiency				
Maximum ⁸⁾	98.8%			
Euro-eta ⁸⁾	98.6%			
CEC efficiency ⁹⁾	98.5%			
Power consumption				
Own consumption in normal operation	5000 W			
Maximum standby operation consumption	460 W			
Auxiliary voltage type	external ¹⁰⁾			

¹⁾ DC/AC ratio close to 2.0 might shorten maintenance intervals

²⁾ Throughout the temperature range

³⁾ Standard 24 DC inputs with negative grounding, fuses on positive pole only

⁴⁾ +/- 10%, consult FIMER for detailed information

⁵⁾ +/- 10 Hz

⁶⁾ At nominal power

⁷⁾ Inverter side must be IT type

⁸⁾ Without auxiliary power consumption at min U_{dc}

⁹⁾ Rounded according to CEC rules

¹⁰⁾ Internal available as an option

Technical data and types				
Product	PVS980-58 4.3 MVA	PVS980-58 4.6 MVA	PVS980-58 4.8 MVA	PVS980-58 5.0 MVA
Type designation, PVS980-58	-4348kVA-I	-4565kVA-J	-4782kVA-K	-5000kVA-L
Dimensions and weight				
Width/Height/Depth, mm (W/H/D)	5600/2200/1600			
Weight appr.	Max. 6000 kg			
Environmental limits				
Degree of protection	IP55 /Type 3R, sand test certified.			
Ambient temp. range ¹¹⁾	-20 ... +50 °C			
Maximum ambient temperature ¹²⁾	+60 °C			
Relative humidity	4 ... 100%			
Maximum altitude (above sea level) ¹³⁾	4000m ¹⁴⁾			
Maximum noise level	84 dBA ¹⁵⁾			
Protection				
Ground fault monitoring	Yes			
Grid monitoring	Yes			
Anti-islanding	Yes			
DC reverse polarity	Yes			
AC and DC short circuit and over current	Yes			
AC and DC over voltage and temperature	Yes			
User interface and communications				
Local user interface	Local control panel			
Analog inputs/outputs	2/1 as standard, extendable as engineered option			
Digital inputs/relay outputs	7/1 as standard, extendable as engineered option			
Fieldbus connectivity	Modbus, Profinet, Ethernet IP ¹⁶⁾			
Product compliance				
Safety and EMC	CE Declaration of Conformity, IEC62109-1, IEC62109-2, UL62109, UL1741, CSA C22.2 No. 107.1-16, RCM, IEC62920			
Characteristics	IEC60068-2-1, -2, -14, -30, IEC61683, EN50530, IEC61727, IEC62116, IEC62910, ANSI/UL1998			
Grid codes	IEEE1547-2003, VDE-AR-N 4110, UL1741SA, PO12.2 / NTS, G99, CEA (India), DEWA, Chile			
Grid support and grid functions	Reactive power compensation, Power reduction, LVRT, HVRT, FqRT			

¹¹⁾ -40 °C as option

¹²⁾ Power limiting after 50 °C

¹³⁾ Possible power limiting above 1000 m, depending on temperature

¹⁴⁾ Standard device up to 2000m, up to 4000m as an option

¹⁵⁾ At partial power typically < 75 dBA

¹⁶⁾ More communication options as engineered option

FIMER compact skid IEC version (1500 Vdc) **PVS980-CS**

up to 5000 kVA

The FIMER compact skid is a plug and play solution designed for large-scale solar power generation using PVS980-58 high-power central inverters. It houses all the electrical equipment that is needed to rapidly connect a photovoltaic (PV) power plant to a medium voltage (MV) electricity grid.

Turnkey-solution for PV power plants

The FIMER compact skid design capitalizes on FIMER's long experience in developing and manufacturing solutions for utilities and major end users worldwide in conventional power transmission installations.

A skid houses one 4348 to 5000kVA FIMER PVS980-58 central inverter, an optimized MV oil immersed transformer, MV switchgear and all needed auxiliary services. The FIMER compact skid is used to connect a PV power plant to a MV electricity grid easily and rapidly. To meet the PV power plant's demanded capacity, several FIMER compact skids can be used.

Compact design eases transportation

The compact skid solution has dimensions suitable for transportation inside closed 40 feet High Cube (HC) shipping container. The total package weighs less than 24 tons. The standardized shipping dimensions ensures cost-effective and safe transportability to the site, even overseas. Inverter's optimized air circulation and filtering system, together with hermetically sealed oil immersed transformer enable installations in various ambient conditions, from harsh desert temperatures to cold and humid environments. The FIMER compact skid is designed for at least 25 years of operation.

Highlights

- Proven technology and reliable components
- Compact and robust design
- Outstanding endurance for outdoor use
- High DC input voltage up to 1500 VDC
- High total efficiency
- Extensive DC and AC side protection
- Self-contained cooling system for inverters
- Modular and serviceable system
- Embedded auxiliary power distribution system
- Extendable manufacturing footprint with fast deliveries
- Global life cycle services and support
- Transportable inside closed 40 feet HC shipping container
- Arc-proof design

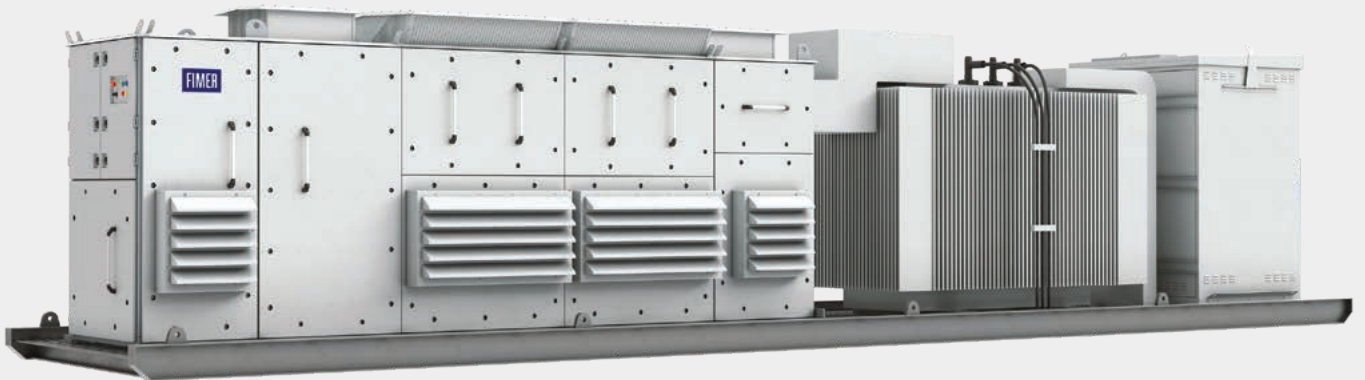

Solar inverters

The FIMER PVS980-58 inverter has been developed on the basis of decades of experience in the industry and proven technology platform. Unrivalled expertise from the world's market and technology leader in frequency converters is the hallmark of this solar inverter series. The PVS980-58 inverter is one of the most efficient and cost-effective ways of converting the direct current (DC) generated by solar modules into high quality and CO₂-free alternating current (AC) that can be fed into the power distribution network. One FIMER central inverter is used in the FIMER compact skid. The inverter provides high conversion efficiency with low auxiliary power consumption, as well as very low maintenance need.

Transformer

The FIMER compact skid includes an oil immersed transformer. The transformer is designed to meet the reliability, durability and

efficiency required in PV applications. It is specifically designed and optimized for the PVS980-58 inverter to provide the best performance throughout the lifetime of the plant.

Different power transformers are available to meet customer requirements. All transformers are manufactured in accordance with the most demanding industry and international standards.

Switchgear

The FIMER compact skid is equipped, as standard, with the widely proven SF₆-insulated switchgear.

A sealed steel tank with constant atmospheric conditions ensures a high level of reliability as well as personnel safety. The virtually maintenance-free system comes in a compact and flexible design that allows for a versatile switchgear configuration with arc-proof capability.

Technical data and type

Type code	4.3MVA	4.6MVA	4.8MVA	5.0MVA
Maximum rating in kVA	4348	4565	4782	5000
Inverter				
Inverter	PVS980-58, 4.3-5MVA			
Maximum operating DC input voltage	1500 V			
Number of inverters	1	1	1	1
Number of independent MPPT	1	1	1	1
MPPT range @ 25° C in V	850-1350	893-1350	935-1350	978-1350
MPPT range @ 35° C in V	850-1250	893-1250	935-1250	978-1250
MPPT range @ 50° C in V	850-1100	893-1100	935-1100	978-1100
AC output voltage	600 V	630 V	660 V	690 V
MV transformer				
Transformer type	Oil immersed (ONAN)			
AC Power @ 25° C in kVA	4343	4565	4782	5000
AC Power @ 35° C in kVA	4229	4441	4652	4864
AC Power @ 50° C in kVA	3845	4037	4229	4421
Number of secondary windings	1	1	1	1
Low voltage level	600 V	630 V	660 V	690 V
Medium voltage level range	≤ 36 kV			
Rated frequency	50Hz or 60 Hz			
Oil type	Mineral (vegetable optional)			
Tap changer	± 2 x 2.5%			
Winding material (primary / secondary)	Al / Al			
Eco efficiency optional	Yes			
MV switchgear				
Switchgear type	SF6-insulated			
Rated current	630 A			
Configuration	Single (CV) or double feeder (CCV)			
Protection (up to 24 kV / up to 36 kV)	Circuit breaker (16 kA or 20 kA / 20 kA or 25 kA)			
Protection relay type	REJ603 (others on request)			
Motorized optional	Yes			
Auxiliary supply				
Auxiliary transformer power	10 kVA (higher on request)			
Auxiliary transformer primary voltage level	600 V	630 V	660 V	690 V
Auxiliary transformer secondary voltage level	400-230 V			
Low voltage distribution panel for auxiliary functions	Yes			
Mechanical characteristics				
Transport dimensions (length x width x height) in mm	11850 x 2150 x 2570 (40ft HC container dimensions)			
Weight approx. in ton	24			
Environmental				
Operating temperature range	-20° C ... +50° C			
Operating altitude range	≤ 2000 m			
Relative humidity (non-condensing)	≤ 95%			
Environmental protection rating	IP 54 (IP 55 for inverter)			
Painting corrosion protection	C4			
Product compliance				
Conformity	IEC 60364, IEC 61936-1, IEC 60502-1			
Grid support	Reactive power compensation (also at night), power reduction, LVRT, HVRT, FqRT			

FIMER compact skid for US market (1500 Vdc) **PVS980-CS-US**

up to 5000 kVA

The FIMER compact skid is a plug-and-play solution designed for large-scale solar power generation using PVS980-58 high-power central inverters. It houses all the electrical equipment that is needed to rapidly connect a photovoltaic (PV) power plant to a medium voltage (MV) electricity grid.

Turnkey-solution for PV power plants

The FIMER compact skid design capitalizes on FIMER's long experience in developing and manufacturing solutions for utilities and major end users worldwide in conventional power transmission installations.

A skid houses one 4348 to 5000kVA FIMER PVS980-58 central inverter, an optimized MV oil immersed transformer and all needed auxiliary services. The FIMER compact skid is used to connect a PV power plant to a MV electricity grid easily and rapidly. To meet the PV power plant's demanded capacity, several FIMER compact skids can be used.

Compact design eases transportation

The compact skid solution supports fast on-site installation with easy transportation to project sites. Transport of the skid can be done with a standard truck and can be set in place with a standard crane for a simple installation. Inverter's optimized air circulation and filtering system, together with hermetically sealed oil immersed transformer enable installations in various ambient conditions, from harsh

desert temperatures to cold and humid environments.

This skid mounted solution is pre-assembled on a factory built steel or concrete foundation. With pre-configured layout options a minimal footprint can be achieved.

The FIMER compact skid is designed for at least 25 years of operation.

Highlights

- Proven technology and reliable components
- Compact and robust design
- Outstanding endurance for outdoor use
- High DC input voltage up to 1500 Vdc
- High total efficiency
- Extensive DC and AC side protection
- Self-contained cooling system for inverters
- Modular and serviceable system
- Embedded auxiliary power distribution system
- Extendable manufacturing footprint with fast deliveries
- Global life cycle services and support
- Arc-proof design



Technical data and type

Type code	4.3MVA	4.6MVA	4.8MVA	5.0MVA
Maximum rating in kVA	4348	4565	4782	5000
Inverter				
Inverter	PVS980-58, 4.3-5MVA			
Maximum operating DC input voltage	1500 V			
Number of protected DC inputs	24-36			
Number of inverters	1	1	1	1
Number of independent MPPT	1	1	1	1
MPPT range @ 25° C in V	850-1350	893-1350	935-1350	978-1350
MPPT range @ 35° C in V	850-1250	893-1250	935-1250	978-1250
MPPT range @ 50° C in V	850-1100	893-1100	935-1100	978-1100
AC output voltage	600 V	630 V	660 V	690 V
MV transformer				
Transformer type	3-phase Pad-Mounted, Oil Filled, UL Listed			
AC Power @ 25° C in kVA	4348kVA	4565	4782	5000
AC Power @ 35° C in kVA	4229	4441	4652	4864
AC Power @ 50° C in kVA	3845	4037	4229	4421
Number of secondary windings	1	1	1	1
Low voltage level	600 V	630 V	660 V	690 V
Medium voltage level range	12.47kV to 34.5kV			
LV terminals	6-hole integral spade bushings, side mounted for close coupled connection			
HV terminals	600A dead-break bushings (dead front), loop feed or radial feed			
Rated frequency	60 Hz			
Cooling Class ¹⁾	ONAN			
Fluid ²⁾	Mineral Oil			
Tap changer	± 2 x 2.5%			
Winding material (primary / secondary)	Al / Al			
Protection ³⁾	Current Limiting Fuse & Weak Link Cartridge (based on HV kV rating)			
Eco efficiency optional	Yes			
Switches	2-Position 300A LBOR transformer switch			
Monitoring ⁴⁾	Pressure relief valve, liquid level, liquid temperature & pressure vacuum gauges with alarm contacts			
Fittings	External drain valve in padlockable box			

1) KNAN optional

2) Natural Ester Fluid Optional

3) Molded Vacuum Interrupter (MVI) optional below 34.5kV HV rating

4) Includes liquid temperature gauge and pressure vacuum gauge with 2 sets of alarm contacts

Technical data and type

Type code	4.3MVA	4.6MVA	4.8MVA	5.0MVA
Auxiliary equipment				
Power (Standard)	1-phase output, 115-120VAC, 4 kVA power, 50 A disconnect switch for protection			
Power (Optional) ⁵⁾	3-phase output, max 60 A, rated disconnect switch, auxiliary step-down transformer, 3-phase output, 208/120V, 10kVA customer auxiliary power output available			
Environmental				
Ambient temperature range ⁶⁾	-20° C ... +50° C			
Altitude ⁷⁾	up to 4000 m			
Physical				
Base	Open Steel Beam or Concrete			
Width/Height/Depth (approximate)	8'-6" x 9'-8" x 27'-10"			
Mounting	Pad-Mount or Pier Mount			
Environmental Protection Rating	NEMA Type 3R			

5) Voltage based on inverter output, rated power panelboard per customer specifications

6) Extend range -40C optional

7) Derating above 1000m

FIMER central inverter (1500 Vdc) PVS980-58

up to 2300 kVA

FIMER high power central inverters raise the performance, cost efficiency and ease of installation to new levels. The inverters are aimed at system integrators and end users who require high-performance solar inverters for large photovoltaic (PV) power plants. PVS980-58 central inverters are now available from 1818 kVA up to 2300 kVA, and are optimized for multi-megawatt power plants.

World's leading inverter platform

Like other FIMER central inverters, the PVS980-58 has been developed on the basis of decades of experience in the industry and proven technology platform. Unrivalled expertise from the world's market and technology leader in frequency converters is the hallmark of this solar inverter series.

The PVS980-58 inverter is one of the most efficient and cost-effective ways of converting the direct current (DC) generated by solar modules into high quality and CO₂-free alternating current (AC) that can be fed into the power distribution network.

PVS980-58 central inverters from FIMER

PVS980-58 central inverters are ideal for large PV power plants. The high DC input voltage, high efficiency, proven components, compact and modular design and a host of life cycle services ensure FIMER PVS980-58 central inverters provide a rapid return on investment.

Highlights

- Patented, self-contained cooling system with high efficiency
- High total performance
- Outstanding endurance for outdoor use
- Compact, modular product design
- High DC input voltage up to 1500 VDC
- Extensive DC and AC side protection
- Versatile design for large-scale PV plants to minimize system costs
- Complete range of industrial data communication options, including remote monitoring
- Life cycle service and support through FIMER's extensive global service network solar inverters



Maximum energy revenues

FIMER central inverters have a high total efficiency. Precise, optimized system control and maximum power point tracking (MPPT) combined with the unit's highly efficient power converter design deliver the maximum energy from the PV modules to the power distribution network. For end users, this generates the highest possible revenues from the energy sales.

Self-contained, low-maintenance cooling system

PVS980-58 inverters feature a proven closed loop cooling system used in other industrial applications.

This innovative, low-maintenance cooling solution is designed for demanding applications and harsh environments, cutting maintenance costs and ensuring outstanding endurance.

Compact and modular design

PVS980-58 inverters are designed for fast and easy installation. The industrial design and modular platform provide a wide range of options, such as remote monitoring, fieldbus connection and modular and flexible DC input connections.

The integrated DC cabinet saves space and costs as the solar array junction boxes can be connected directly to the fused busbars in the DC cabinet. PVS980-58 inverters are customized

for the needs of end users and will be available with short delivery times.

Versatile design for large-scale PV plants to minimize system costs

FIMER's PVS980-58 central inverters enable system integrators to design PV power plants that use the optimum combination of inverters with different power ratings. Equipped with extensive electrical and mechanical protection, the inverters are engineered to provide a long and reliable service life of at least 25 years.

Advanced grid support features

The PVS980-58 software includes all the latest grid support and monitoring features, including active power limitation, fault ride through (FRT) with current feed-in and reactive power control.

Active and reactive power output can be controlled by an external control system or automatically by the inverter. All grid support functions are parameterized, allowing easy adjusting for local utility requirements. FIMER central inverters are also able to support grid stability at night by providing reactive power with the DC input disconnected.

Technical data and types

Product Type designation	PVS980-58 2.0 MVA -1818kVA-I	PVS980-58 2.1 MVA -1909kVA-J	PVS980-58 2.2 MVA -2000kVA-K	PVS980-58 2.3 MVA -2091kVA-L
Input (DC)				
Maximum recommended PV power ($P_{PV, max}$) ¹⁾	2909 kWp	3056 kWp	3200 kWp	3346 kWp
Maximum DC current ($I_{max(DC)}$)	2400 A	2400 A	2400 A	2400 A
DC voltage range, mpp ($U_{DC, mpp}$) at 35 °C	850 to 1500 V	893 to 1500 V	935 to 1500 V	978 to 1500 V
DC voltage range, mpp ($U_{DC, mpp}$) at 50 °C	850 to 1100 V	893 to 1100 V	935 to 1100 V	978 to 1100 V
Maximum DC voltage ($U_{max(DC)}$)	1500 V	1500 V	1500 V	1500 V
Number of MPPT trackers	1	1	1	1
Number of protected DC inputs	8 ²⁾ to 24 (+/-)	8 ²⁾ to 24 (+/-)	8 ²⁾ to 24 (+/-)	8 ²⁾ to 24 (+/-)
Output (AC)				
Maximum power ($S_{max(AC)}$) ³⁾	2000 kVA	2100 kVA	2200 kVA	2300 kVA
Nominal power ($S_{N(AC)}$) ⁴⁾	1818 kVA	1909 kVA	2000 kVA	2091 kVA
Maximum AC current ($I_{max(AC)}$)	1925 A	1925 A	1925 A	1925 A
Nominal AC current ($I_{N(AC)}$)	1750 A	1750 A	1750 A	1750 A
Nominal output voltage ($U_{N(AC)}$) ⁵⁾	600 V	630 V	660 V	690 V
Output frequency ⁵⁾	50/60 Hz	50/60 Hz	50/60 Hz	50/60 Hz
Harmonic distortion, current ⁶⁾	< 3%	< 3%	< 3%	< 3%
Distribution network type ⁷⁾	TN and IT	TN and IT	TN and IT	TN and IT
Efficiency				
Maximum ⁸⁾	98.8%	98.8%	98.8%	98.8%
Euro-eta ⁸⁾	98.6%	98.6%	98.6%	98.6%
CEC efficiency ⁹⁾	98.0%	98.5%	98.5%	98.5%
Power consumption				
Self consumption in normal operation	≤ 2500 W	≤ 2500 W	≤ 2500 W	≤ 2500 W
Standby operation consumption	235 W	235 W	235 W	235 W
Auxiliary voltage source ¹⁰⁾	External, 1-phase	External, 1-phase	External, 1-phase	External, 1-phase
Environmental limits				
Degree of protection	IP66 ¹¹⁾ / UL Type 3R			
Ambient temp. range (nom. ratings) ¹²⁾	-20 °C to +50 °C			
Maximum ambient temperature ¹³⁾	+60 °C			
Relative humidity	5% to 100%			
Maximum altitude (above sea level)	4000 m ¹⁴⁾			
Typical sound pressure level (at 1 m distance)	< 75 dB (A) ¹⁵⁾			
Maximum sound pressure level (at 1 m distance)	< 88 dB (A) ¹⁵⁾			
Local user interface	Control panel			
Analog inputs	2 as standard			
Digital inputs/relay outputs	7/1 as standard			
Fieldbus connectivity	Modbus, Profinet, Ethernet ¹⁶⁾			
Product compliance				
Safety and EMC ¹⁶⁾	CE conformity according to LV and EMC directives			
Certifications and approvals	IEC, UL, CSA, RCM, IEEE, BDEW, CEI, SAGC, FCC and more			
Grid support and grid functions	Reactive power compensation ¹⁷⁾ , Power reduction, LVRT, HVRT, FqRT			
Dimensions and weight				
Width/Height/Depth, mm (W/H/D)	3180/2443/1522	3180/2443/1522	3180/2443/1522	3180/2443/1522
Weight appr.	3500 kg	3500 kg	3500 kg	3500 kg

¹⁾ DC/AC ratio over 1.6 might decrease maintenance intervals

²⁾ As standard

³⁾ At 35 °C

⁴⁾ At 50 °C

⁵⁾ ±10%

⁶⁾ At nominal power

⁷⁾ Inverter side must be IT type

⁸⁾ Without auxiliary power consumption at min U_{DC}

⁹⁾ With auxiliary power included

¹⁰⁾ Internal as option

¹¹⁾ Excluding underpressure testing, IP56 with underpressure

¹²⁾ -40 °C as option

¹³⁾ Power derating after 50 °C

¹⁴⁾ Power derating above 1000 m

¹⁵⁾ A - weighted

¹⁶⁾ More communication options as engineered option

¹⁷⁾ Also at night

FIMER bidirectional converter (1500 Vdc) **PVS980-58BC**

up to 2300 kVA

FIMER bidirectional converter PVS980-58BC is aimed at large-scale grid connected energy storage applications. The converters are available from 1454 kVA up to 2300 kVA. PVS980-58BC bidirectional converter is based on the world's leading converter platform used also in FIMER solar inverters ensuring high performance, reliability and availability of global service support.

World's leading converter platform

Like FIMER central inverters, the PVS980-58BC bidirectional converter has been developed on the basis of decades of experience in the industry and proven technology platform. Unrivalled expertise from the world's market and technology leader in frequency converters is the hallmark of the PVS980-58BC series.

PVS980-58BC bidirectional converter from FIMER

FIMER PVS980-58BC bidirectional converters are ideal for multi-megawatt energy storage systems, providing maximum grid stability for power plants with intermittent energy sources. For power plants combining photovoltaics and energy storage, the common platform shared with PVS980-58BC bidirectional converter and PVS980-58BC central inverter brings synergies in both the availability of service and support personnel and the spare part logistics.

Highlights

- Patented, self-contained cooling system suitable for harsh environments
- High total performance
- Outstanding endurance for outdoor use
- Full four quadrant active power and reactive power support
- High DC input voltage up to 1500 VDC for minimizing system cost
- Compact, modular product design
- Life cycle service and support through FIMER's extensive global service network



Technical data and type

Product Type designation	PVS980-58BC -1454kVA-E	PVS980-58BC -1575kVA-F	PVS980-58BC -1696kVA-G	PVS980-58BC -1818kVA-I	PVS980-58BC -1909kVA-J	PVS980-58BC -2000kVA-K	PVS980-58BC -2091kVA-L
Input (DC)							
Full power DC voltage range, (U_{DC}) a 50 °C ¹⁾	680 to 880 V	737 to 950 V	794 to 1020 V	850 to 1100 V	893 to 1100 V	935 to 1100 V	978 to 1100 V
DC voltage operating range, (U_{DC}) ¹⁾	680 to 1500 V	737 to 1500 V	794 to 1500 V	850 to 1500 V	893 to 1500 V	935 to 1500 V	978 to 1500 V
Maximum DC voltage ($U_{max(DC)}$)	1500 V	1500 V	1500 V	1500 V	1500 V	1500 V	1500 V
Maximum DC current ($I_{max(DC)}$) at 35 °C	2400 A	2400 A	2400 A	2400 A	2400 A	2400 A	2400 A
Maximum DC current ($I_{max(DC)}$) at 50 °C	2182 A	2182 A	2182 A	2182 A	2182 A	2182 A	2182 A
Number of DC inputs	8 inputs, as option 12 inputs or 16 inputs (+/-) and DC input current measurement						
Max DC short circuit withstand	73 kApeak, 17 MA ² s, external aR fuses required between converter and BES						
DC grounding	Floating only						
DC surge arrester	Type 2 as standard. High Energy Type 1 as option						
DC disconnecter	as option						
Output (AC)							
Output power ($S_{max(AC)}$) at 50 °C	1454 kVA	1575 kVA	1696 kVA	1818 kVA	1909 kVA	2000 kVA	2091 kVA
Nominal power ($S_{N(AC)}$) at 35 °C	1600 kVA	1733 kVA	1866 kVA	2000 kVA	2100 kVA	2200 kVA	2300 kVA
Maximum AC current ($I_{max(AC)}$) at 50 °C	1750 A	1750 A	1750 A	1750 A	1750 A	1750 A	1750 A
Maximum AC current ($I_{max(AC)}$) at 35 °C	1925 A	1925 A	1925 A	1925 A	1925 A	1925 A	1925 A
Nominal output voltage ($U_{N(AC)}$) ²⁾	480 V	520 V	560 V	600 V	630 V	660 V	690 V
Output frequency	50/60 Hz	50/60 Hz	50/60 Hz	50/60 Hz	50/60 Hz	50/60 Hz	50/60 Hz
Harmonic distortion, current ³⁾	< 3%	< 3%	< 3%	< 3%	< 3%	< 3%	< 3%
Distribution network type	IT	IT	IT	IT	IT	IT	IT
Power factor	Four quadrant						
AC disconnecter / AC breaker	as option						
AC surge arrester	Type 2 as standard. High Energy Type 1 as option						
Efficiency							
Maximum ⁴⁾	98.6%	98.7%	98.7%	98.8%	98.8%	98.8%	98.8%
Auxiliary power consumption							
Max. own consumption in operation	2500 W	2500 W	2500 W	2500 W	2500 W	2500 W	2500 W
Standby operation consumption	235 W	235 W	235 W	235 W	235 W	235 W	235 W
Auxiliary voltage source	External, 1 phase auxiliary power input ⁵⁾						

1) Minimum DC ($U_{DC,min}$) for $U_{N(AC)}$ and power factor=1. The minimum DC voltage depends on AC voltage and power factor. The AC dependency follows formula $U_{DC,min} = U_{AC} * \sqrt{2} * 1.002$ with PF=1. Contact FIMER for more information.

2) ±10%

3) At nominal active power

4) Without auxiliary power consumption at min U_{DC}

5) As option internal auxiliary power (internal transformer from inverter output)

Technical data and type

Product	PVS980-58BC	PVS980-58BC	PVS980-58BC	PVS980-58BC	PVS980-58BC	PVS980-58BC	PVS980-58BC
Type designation	-1454kVA-E	-1575kVA-F	-1696kVA-G	-1818kVA-I	-1909kVA-J	-2000kVA-K	-2091kVA-L
Dimensions and weight							
Width/Height/Depth, mm (W/H/D)	3180/2443/1522						
Weight appr.	3500 kg						
Environmental limits							
Degree of protection ⁶⁾	IP66/UL Type 3R						
Ambient temp. range (nom. ratings) ⁷⁾	-20 °C to +50 °C						
Maximum ambient temperature ⁸⁾	+60 °C						
Relative humidity	5% to 100%						
Maximum altitude (above sea level) ⁹⁾	4000 m						
Maximum sound pressure level ¹⁰⁾	88 dBA						
Protection							
Ground fault monitoring	Yes						
Grid monitoring	Yes						
Anti-islanding	Yes						
DC reverse polarity	Yes						
AC/DC short circuit and overcurrent ¹¹⁾	Yes						
AC/DC overvoltage and temperature	Yes						
Energy Storage firmware							
PQ setpoints	Yes						
Start and stop sequence for battery energy storage system	Yes						
User interface and communications							
Local user interface	Local control panel						
Analog inputs	2 as standard						
Digital inputs/relay outputs	7/1 as standard						
Fieldbus connectivity ¹²⁾	Modbus, Profinet, Ethernet						
Product compliance ¹³⁾							
Safety and EMC	CE according to LV and EMC directives						
Certifications and approvals	IEC, UL, CSA, RCM, IEEE, BDEW, CEI, SAGC, FCC						
Grid support and grid functions	Reactive power compensation, Power reduction, LVRT, HVRT, FqRT, Anti-islanding						

6) IP66 excluding under pressure testing, IP56 with under pressure

7) -40 °C as option

8) Power derating after 50 °C

9) Derating above 1000 m, as option above 2000 m

10) A-weighted Sound pressure level at 1m

At partial power typically < 75 dB

11) DC short circuit protection with external aR fuses

12) More communication options as engineered option

13) Approvals pending, contact FIMER for more information

Coupled Storage System

PVS980-58 DC

FIMER's PVS980-58 central inverter provides the most robust and reliable Utility-Scale DC-Coupled Storage System through our partnership with Dynapower.

The PVS980-58 DC-Coupled Storage System combines state-of-the-art PVS980-58 2 and 5MVA central inverters with Dynapower's advanced DPS-500 bi-directional DC/DC converter.



Key features

- Utilization of high DC to AC ratio benefit due to high short circuit rating of PVS980 solar inverters
- Retrofitting of existing PVS980 plants with energy storage option
- Modular concept for simple and easy expandability of Energy storage portion afterwards

Advantages of DC-Coupled Storage

- Solar Peak Energy Re-capture
- Low-Voltage Harvesting
- Demand Charge Management
- Improved round trip efficiency of stored energy
- Storing clipped power to battery
- Optimal utilization of high DC/AC ratios
- Reduced AC interconnection scope

Best suited applications

- Energy-time shifting
- Capacity firming
- Ramp-rate control

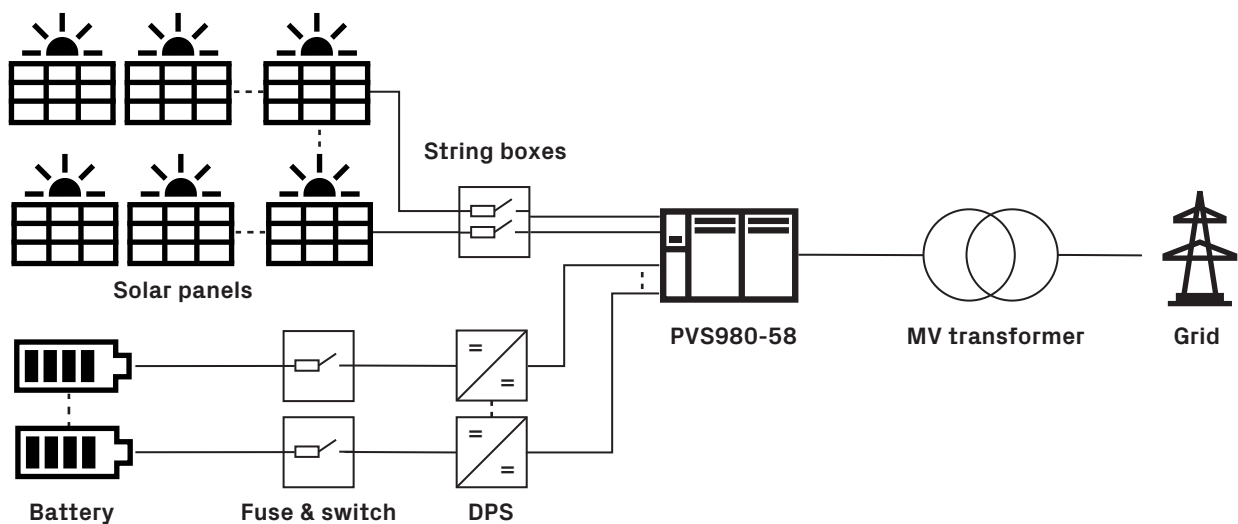

Specifications

PVS980-58 4.3 - 5MVA central inverter

Inverter type	-4348kVA-I	-4565kVA-J	-4782kVA-K	-5000kVA-L
Maximum input voltage				1500 Vdc
Max Power Voltage Range (MPPT) (Ⓜ+25C)	850 - 1350 Vdc	893 - 1350 Vdc	935 - 1350 Vdc	978 - 1350 Vdc
Operating Voltage Range	850 - 1500 Vdc	893 - 1500 Vdc	935 - 1500 Vdc	978 - 1500 Vdc
Max Operating Input Current				5300 A
Maximum Operating PV Power	8696 kWdc	9130 kWdc	9564 kWdc	10000 kWdc
Nominal Output Voltage	600 Vac	630 Vac	660 Vac	690 Vac
Continuous Real/Apparent Power Output (Ⓜ+25C) (max)	4348 kW/4348 kVA	4565 kW/4565 kVA	4782 kW/4782 kVA	5000 kW/5000 kVA
Maximum Output Current (Ⓜ+25C)				4184 A
Maximum Efficiency				98.8 %
Certifications *	UL62109, UL1741, CSA C22.2 No. 107.1-16, ANSI/UL1998, IEEE1547-2003, VDE-AR-N 4110, UL1741SA			

*See flyer and HW manual for complete list of certifications

PVS980-58 2.0 - 2.3MVA central inverter

Inverter type	-1818kVA-I	-1909kVA-J	-2000kVA-K	-2091kVA-L
Maximum input voltage				1500 Vdc
Max Power Voltage Range (MPPT) (Ⓜ+25C)	850 - 1500 Vdc	893 - 1500 Vdc	935 - 1500 Vdc	978 - 1500 Vdc
Operating Voltage Range	850 - 1500 Vdc	893 - 1500 Vdc	935 - 1500 Vdc	978 - 1500 Vdc
Max Operating Input Current				2400 A
Maximum Operating PV Power	2909 kWdc	3056 kWdc	3200 kWdc	3346 kWdc
Nominal Output Voltage	600 Vac	630 Vac	660 Vac	690 Vac
Continuous Real/Apparent Power Output (max)	1818 kW/1818 kVA	1909 kW/1909 kVA	2000 kW/2000 kVA	2091 kW/2091 kVA
Maximum Output Current (Ⓜ+35C)				1925 A
Maximum Efficiency				98.8 %
Certifications *	UL62109, UL1741, CSA C22.2 No. 107.1-16, ANSI/UL1998, IEEE1547-2003, VDE-AR-N 4110, UL1741SA			

*See flyer and HW manual for complete list of certifications



Dynapower DC-DC converter specifications

	DPS-500
DC Input Voltage Range (Battery Port)	100-1500 Vdc
DC Input Voltage Range (PV Port)	100-1500 Vdc
Max Continuous Power Rating at 30C	600 kWdc
Max Continuous Current Rating	500 A
Avg Efficiency	99%
Operating Temperature Range	-25 to +50 °C
Certifications	UL 1741, UL62109-1, FCC Part 15, class A, IEC 62109-1, IEC 62109-2, IEC/EN61000-6-2, IEC/EN61000-6-4, CISPR11 2015-6

Options

- Integrated and flexible DC input extension
- Heavy duty (Type 1) surge protection
- Internal auxiliary power supply
- Fieldbus and Ethernet connections
- Customized DC Integration hubs / re-combiners
- High Accuracy DC Metering (0.2%)
- DC Fusing

Related products

- Medium voltage station (transformer and switchgear) as outdoor solution
- String monitoring junction boxes with and without monitoring
- Remote monitoring solutions

Support and service

FIMER supports its customers with a global service network and provides a complete range of life cycle services from installation and commissioning to preventative maintenance, spare parts, repairs and recycling.

FIMER compact skid IEC version (1500 Vdc) PVS980-CS up to 4600 kVA

The FIMER compact skid is a compact plug and play solution designed for large-scale solar power generation using PVS980-58 high-power central inverters. The station houses all the electrical equipment that is needed to rapidly connect a photovoltaic (PV) power plant to a medium voltage (MV) electricity grid.

Turnkey-solution for PV power plants

The FIMER compact skid design capitalizes on FIMER's long experience in developing and manufacturing solutions for utilities and major end users worldwide in conventional power transmission installations.

A skid houses one or two outdoor 1818 to 2091 kVA FIMER PVS980-58 central inverters, an optimized MV oil immersed transformer, MV switchgear and all needed auxiliary services. The FIMER compact skid is used to connect a PV power plant to a MV electricity grid easily and rapidly. To meet the PV power plant's demanded capacity, several FIMER compact skids can be used.

Compact design eases transportation

The compact skid solution has dimensions suitable for transportation inside closed 40 feet High Cube shipping container. The total package weighs less than 24 tons. The standardized shipping dimensions ensures cost-effective and safe transportability to the site, even overseas. Inverter's optimized air circulation and filtering system, together with hermetically sealed oil immersed transformer enable installations in various ambient conditions, from harsh desert temperatures to cold and humid environments. The FIMER compact skid is designed for at least 25 years of operation.

Highlights

- Proven technology and reliable components
- Compact and robust design
- Outstanding endurance for outdoor use
- High DC input voltage up to 1500 V_{dc}
- High total efficiency
- Extensive DC and AC side protection
- Self-contained cooling system for inverters
- Modular and serviceable system
- Embedded auxiliary power distribution system
- Extendable manufacturing footprint with fast deliveries
- Global life cycle services and support
- Transportable inside closed 40 feet HC shipping container
- Arc-proof design



Technical data and type

Type code	2.0MVA	2.1MVA	2.2MVA	2.3MVA	4.0MVA	4.2MVA	4.4MVA	4.6MVA
Maximum rating in kVA	2000	2100	2200	2300	4000	4200	4400	4600
Inverter								
Inverter	PVS980-58, 2.0 - 2.3MVA							
Maximum operating DC input voltage	1500 V							
Number of inverters	1	1	1	1	2	2	2	2
Number of independent MPPT	1	1	1	1	2	2	2	2
MPPT range @ 35° C in V	850-1500	893-1500	935-1500	978-1500	850-1500	893-1500	935-1500	978-1500
MPPT range @ 50° C in V	850-1100	893-1100	935-1100	978-1100	850-1100	893-1100	935-1100	978-1100
AC output voltage	600 V	630 V	660 V	690 V	600 V	630 V	660 V	690 V
MV transformer								
Transformer type	Oil immersed (ONAN)							
AC Power @ 35° C in kVA	2000	2100	2200	2300	4000	4200	4400	4600
AC Power @ 50° C in kVA	1818	1909	2000	2091	3636	3818	4000	4182
Number of secondary windings	1	1	1	1	2	2	2	2
Low voltage level	600 V	630 V	660 V	690 V	600 V	630 V	660 V	690 V
Medium voltage level range	≤ 36 kV							
Rated frequency	50Hz or 60 Hz							
Oil type	Mineral (vegetable optional)							
Tap changer	± 2 x 2.5%							
Winding material (primary / secondary)	Al / Al							
Eco efficiency optional	Yes							
MV switchgear								
Switchgear type	SF6-insulated							
Rated current	630 A							
Configuration	Single (CV) or double feeder (CCV)							
Protection (up to 24 kV / up to 36 kV)	Circuit breaker (16 kA or 20 kA / 20 kA or 25 kA)							
Protection relay type	REJ603 (others on request)							
Motorized optional	Yes							

Technical data and type

Type code	2.0MVA	2.1MVA	2.2MVA	2.3MVA	4.0MVA	4.2MVA	4.4MVA	4.6MVA
Auxiliary supply								
Auxiliary transformer power	10 kVA (20kVA, 30kVA optional)							
Auxiliary transformer primary voltage level	600 V	630 V	660 V	690 V	600 V	630 V	660 V	690 V
Auxiliary transformer secondary voltage level	400-230 V							
Low voltage distribution panel for auxiliary functions	Yes							
Mechanical characteristics								
Dimensions (length x width x height) in mm	11850 x 2150 x 2570 (40ft HC container dimensions)							
Weight approx. in ton	17	17	17	17	24	24	24	24
Environmental								
Operating temperature range	-20° C ... +50° C							
Operating altitude range	≤ 2000 m							
Relative humidity (non-condensing)	≤ 95%							
Environmental protection rating	IP 54 (IP 66 for inverter)							
Painting corrosion protection	C4 (C5M optional)							
Product compliance								
Conformity	IEC 60364, IEC 61936-1, IEC 60502-1							
Grid support	Reactive power compensation (also at night), power reduction, LVRT, HVRT, FqRT							

FIMER compact skid for US market (1500 Vdc) PVS980-CS-US

up to 4400 kVA

The FIMER compact skid is a plug and play solution designed for large-scale solar power generation using PVS980-58 high-power central inverters. It houses all the electrical equipment that is needed to rapidly connect a photovoltaic (PV) power plant to a medium voltage (MV) electricity grid.

Turnkey-solution for PV power plants

The FIMER compact skid design capitalizes on FIMER's long experience in developing and manufacturing solutions for utilities and major end users worldwide in conventional power transmissions installations. It is made to meet the safety and electrical installation standards for USA markets.

The design is optimized to provide cost-effective transportation as well as fast and easy installation on site.

The FIMER compact skid is used to connect a PV power plant to a MV electricity grid easily and rapidly. To meet the PV power plant's demanded capacity, several FIMER compact skids can be used.

All the components within this medium voltage skid come from FIMER's product portfolio to meet the performance and quality standards required for solar applications. The skid is a cost-effective solution with easy in-lands transportability package for PV power plants.

The FIMER medium voltage skid mounted design capitalizes on FIMER's long experience in developing and manufacturing medium voltage components for utility-scale solutions for major end-users worldwide in conventional power transmission installations. The solution contains an optimized transformer, optional DC disconnection cabinet and signaling interfaces for the PVS980 inverter. PVS980 central inverter together with the skid mounted solution ensures easy and rapid connection of the inverters to a plant's medium voltage grid and its communication network

Compact and robust design for harsh environments

This skid mounted solution is pre- assembled on a factory built steel or concrete foundation.

The design enables operation in harsh temperature and humidity environments and is designed for at least 25 years of operation. The FIMER medium voltage skid mounted solution supports fast on-site installation and it is easy to transport inlands. Transport of the skid can be done with a standard truck and lifted to site as one transport unit, which simplifies the installation. Together with pre-configured layout options a minimal footprint and optimum cabling can be achieved.

Highlights

- Reliability – proven components from one supplier
- Transportability – compact and robust design
- Plug-and-play – integrated signaling interfaces
- Increased uptime – modular and serviceable system
- Bankable solution – global life cycle services and support



Technical data and type

Compact Skid Type	PVS980-CS-2000kVA-US-K-XX	PVS980-CS-4000kVA-US-K-XX
Inverter Type ¹⁾	PVS980-58-2000kVA-K	2 x PVS980-58-2000kVA-K
Input (DC)		
Maximum DC Voltage		1500 V
Maximum Combined Input Power	3200 kWp	6400 kWp
Number of Protected DC inputs	24	48
Output (AC)		
Inverter Rated Power (at 50°C/35°C)	2000 kVA / 2200 kVA	4000 kVA / 4400 kVA
Inverter Rated AC Current (at 50°C/35°C)	1750 A / 1925 A	1750 A / 1925 A per inverter
Inverter Rated Output Voltage	660 V	2 x 660 V
Transformer		
Transformer Type ⁴⁾	3-Phase Pad-Mounted, Oil Filled, UL Listed	
Power Rating	2200 kVA	4400 kVA
Winding Configuration	2-winding	3-winding
Cooling Class ²⁾	ONAN	
Fluid ³⁾	Mineral Oil	
Frequency	60 Hz	
Low Voltage	660 V	2 x 660 V
High Voltage	12.47 kV to 34.5 kV	
LV terminals ⁴⁾	6-hole integral spade bushings	6-hole integral spade bushings x 2
HV terminals	600 A dead-break bushings (dead front) x 6	
Fuses	Bay-O-Net with Back-Up Current Limiting	Varies based on high voltage kV rating
Switches	2-position 300A LBOR transformer switch	
Monitoring ⁵⁾	Pressure relief valve, liquid level-, temperature- and pressure gauges with alarm contacts	
Fittings	1" drain valve and sampler located in LV compartment, external drain valve padlockable box	
Auxiliary Equipment		
Power (Standard)	1-phase output, 115-120VAC, 2 kVA power, 20 A disconnect switch for protection	
Power (Optional) ⁶⁾	3-phase output, 660VAC, max 60 A, rated disconnect switch, auxiliary step-down transformer	
Environmental		
Ambient temperature range ⁷⁾	-20°C to +50°C	
Altitude ⁸⁾	up to 4000 m	

Technical data and type

Compact Skid Type	PVS980-CS-2000kVA-US-K-XX	PVS980-CS-4000kVA-US-K-XX
Inverter Type ¹⁾	PVS980-58-2000kVA-K	2 x PVS980-58-2000kVA-K
Physical		
Base	Concrete or Steel	
Width/Height/Depth (approximate)	9'-0" x 8'-10" x 20'-7" (Standard)	9'-6" x 8'-10" x 34'-1" (Standard)
Mounting	Pad-Mount or Pier Mount	
Environmental Protection Rating	NEMA Type 3R (Inverter) & NEMA Type 3R (All other equipment)	
Options		
DC Disconnect	1500VDC, 8-24 inputs, 150 A-400 A switches, Non-Load Break or Load Break, UL Listed	
Oil Containment	Vault or Built-in Pan	

1) See inverter data sheet for inverter type options
 2) KNAN optional
 3) Natural Ester Fluid optional
 4) Sidewall mounted

5) Includes liquid temperature gauge with 2 sets of alarm contacts
 6) Rated power panelboard per customer specifications
 7) Extend range -40°C optional
 8) Derating above 1000 m

FIMER medium voltage pad (1000 and 1500 Vdc) PVS980-MVP

up to 10000 kVA

The FIMER medium voltage pad mounted solution is a cost efficient and robust solution designed for large-scale solar power generation and to be compatible with the PVS980-58 outdoor inverters. It combines the medium voltage transformer and the switchgear equipment needed to connect the inverters to the medium voltage network of the photovoltaic plant.

All the components within this medium voltage pad meet the performance and quality standards required for solar applications.

Cost efficient solution for PV power plants

The FIMER medium voltage pad mounted design capitalizes on FIMER's long experience in developing and manufacturing components for utility scale solutions for major end-users worldwide in conventional power transmission installations. The solution contains an optimized transformer, MV switchgear and signaling interfaces for the PVS980-58 inverter. PVS980-58 inverter together with the PVS980 medium voltage pad mounted solution ensure easy and rapid connection of the inverters to a plant's medium voltage grid and its communication network.

Compact and robust design for harsh environments

This pad mounted solution is to be assembled on an onsite built concrete foundation. The design enables operation in harsh temperature and humidity environments and is designed for at least 25 years of operation.

The FIMER medium voltage pad mounted solution supports fast on-site installation and it is easy to transport. Lifting of components can be done with a standard truck crane, which simplifies the installation. The pre-configured layout options allow for a minimal footprint and optimum cabling.

Highlights

- Reliability – proven components
- Transportability – compact and robust design
- Plug-and-play – integrated signaling interfaces
- Increased uptime – modular and serviceable system
- Bankable solution – global life cycle services and support



Solution

The solution is the result of decades of experience in manufacturing and delivering compact solutions for demanding customer projects all over the world. The solution is made to meet the safety and electrical installation standards of a wide range of markets. The components' compatibility ensures highest standards of quality, performance and durability.

The transformer and switchgear are delivered separate as outdoor versions. The design is optimized to provide easy transportation as well as fast and easy installation on site. The pre-designed pad type concrete foundation layouts for the outdoor type transformer and switchgear optimize the footprint needed and also minimize the cost and on-site works needed. The foundation serves also as a leakage reservoir for the transformer oil.

Transformer

The FIMER medium voltage pad mounted solution is available with an ONAN type oil transformer. The transformer is designed and optimized for PVS980-58 central inverters and for photovoltaic plant load profile to provide the best

performance throughout the lifetime of the plant.

The transformer is also designed to meet the reliability, durability, and efficiency required in PV applications.

Transformers are available in standard sizes that are based on optimized power ratings to meet different climatic conditions and inverter station sizes. The transformers as well as the general design provide excellent mechanical and short-circuit characteristics. Transformers are manufactured in accordance with the most demanding industry and international standards.

Switchgear cabinet

The FIMER medium voltage pad mounted solution is equipped as standard with widely proven SF₆-insulated switchgear. A sealed steel tank with constant atmospheric conditions ensures a high level of reliability as well as personnel safety. The virtually maintenance-free system comes in a compact and flexible design that has a wide range of signaling and protection options. The switchgear comes installed in an IP54 outdoor enclosure that is suitable for harsh environments. The outdoor housing provides easy access for switch maneuvers and increased serviceability. For humid conditions the switchgear can be equipped with hygostat and heater for removal of condensation.

MV switchgear standard configurations for FIMER medium voltage pad mounted solution

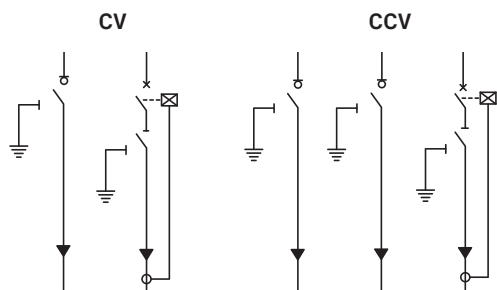

Accessories

- Surge protection for medium voltage side
- Hygostat and heater for medium voltage switchgear
- Transformer LV side terminal box

Options

- Output voltage from 6 kV up to 36 kV
- Different MV switchgear configurations
- Additional transformer and switchgear signaling options
- LV cable set between inverters and transformer
- MV cable set between transformer and medium voltage switchgear
- Warranty extensions
- Service contracts

Support and service

FIMER supports its customers with a dedicated global service network and provides a complete range of life cycle services from installation and commissioning to preventative maintenance, spare parts, repairs and recycling.

Technical data and type

Type designation ¹⁾ PVS980-MVP	-1818kVA- I-xx	-1909kVA- J-xx	-2000kVA- K-xx	-2091kVA- L-xx	-3636kVA-I -xx	-3818kVA- J-xx	-4000kVA- K-xx	-4182kVA- L-xx
General								
Inverter compatibility	PVS980-58-xxxx				2 x PVS980-58-xxxx			
Nominal AC output power ($S_{N(AC)}$) @ 50 °C (122°F)	1818 kVA	1909 kVA	2000 kVA	2091 kVA	3636 kVA	3818 kVA	4000 kVA	4182 kVA
Maximum AC output power ($S_{MAX(AC)}$) @ 35 °C (122°F)	2000 kVA	2100 kVA	2200 kVA	2300 kVA	4000 kVA	4200 kVA	4400 kVA	4600 kVA
Nominal output voltage ($U_{N(AC)}$)	12 kV to 36 kV ²⁾							
Ambient temperature range (nominal ratings) ³⁾	-25 °C to +50 °C							
Maximum altitude (above sea level) ⁴⁾	1000 m							
Switchgear								
Medium voltage switchgear type ⁵⁾	SF ₆ -insulated RMU, CV or CCV, rated 540 A at 50 °C (nominal 630 A)							
Enclosure	Painted Aluzinc coated steel outdoor enclosure, IP54							
Protection relay ⁶⁾	REJ603 protection relay (self-powered)							
Options ⁷⁾	SF ₆ gas alarm, switch positions, plug-in type MV surge protection, automatic cut-off or reclose							
Transformer								
Transformer type	Oil immersed ONAN, outdoor design							
Power rating	1818 kVA	1909 kVA	2000 kVA	2091 kVA	3636 kVA	3818 kVA	4000 kVA	4182 kVA
LV voltage level	600 V	630 V	660 V	690 V	2 x 600 V	2 x 630 V	2 x 660 V	2 x 690 V
MV voltage level	12 kV to 36 kV ²⁾							
LV terminals	3 flag type terminals ⁸⁾				2 x 3 flag type terminals ⁸⁾			
MV terminals	bolted C-type							
Standard protection	2 x temperature, gas, pressure							

1) Where xx-medium voltage level

2) Nominal voltage 12 kV to 36 kV, from 6 kV as option

3) Extended range upon request

4) Higher altitude upon request

5) Other switchgear types available as an option

6) Other relay types upon request

7) Other options upon request

8) LV terminal box available as an option

PVS980 central inverters connectivity solutions



Plant controller & SCADA

PVS980 inverters come with MODBUS/TCP fieldbus interface and MODBUS/RTU communication links as standard. Plug-in connectivity adapters enable communication with all major automation networks.

The inverter supports two Ethernet communication ports simultaneously offering the possibility for ring topology connectivity.

With a local webpage interface the following service can be activated:

- Simple Network Time Protocol (SNTP) for time synchronization
- Remote access with PC tool via Ethernet tool network

Highlights

- Plug-in connectivity adapters enable communication with all major automation networks
- Single point of access to all the inverters
- Ring topology for high reliability



Cost efficient and scalable solutions



Data handling for efficient cloud-solutions



Real-time Monitoring

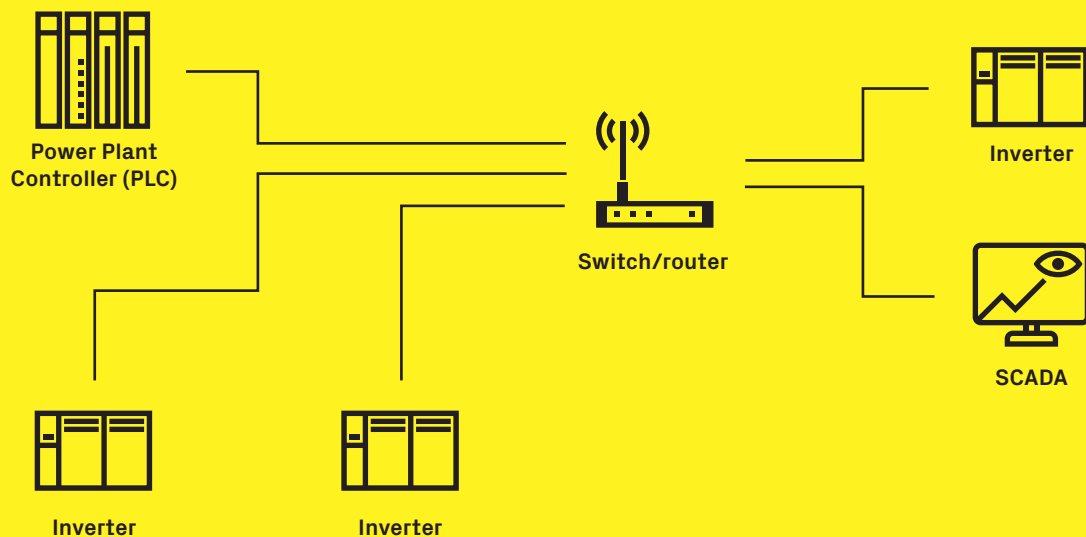

Remote monitoring solutions

Cloud data collection Aurora Vision

Monitor your central inverter solar power plants the way you want with Aurora Vision.

Aurora Vision comes with different products for better meeting the needs of customers aiming to monitor and manage their own solar assets in a very cost-effective manner.

Aurora Vision includes:

- Plant Portfolio Manager: the professional web portal
- Plant Viewer: the simplified web portal
- Plant Viewer for mobile: the mobile app for power generation applications
- Energy Viewer: mobile app for self-consumption applications
- Aurora Vision Application program interface (API): enabling data-sharing with third party systems

Thanks to the simple integration of our gateway VSN900 the central inverters can be connected to the cloud and send data to Aurora Vision.

Highlights

- Easy cloud connection of whole power plant
- Active control of transferred data
- Smart data handling on edge-level for cost-efficient cloud-solutions

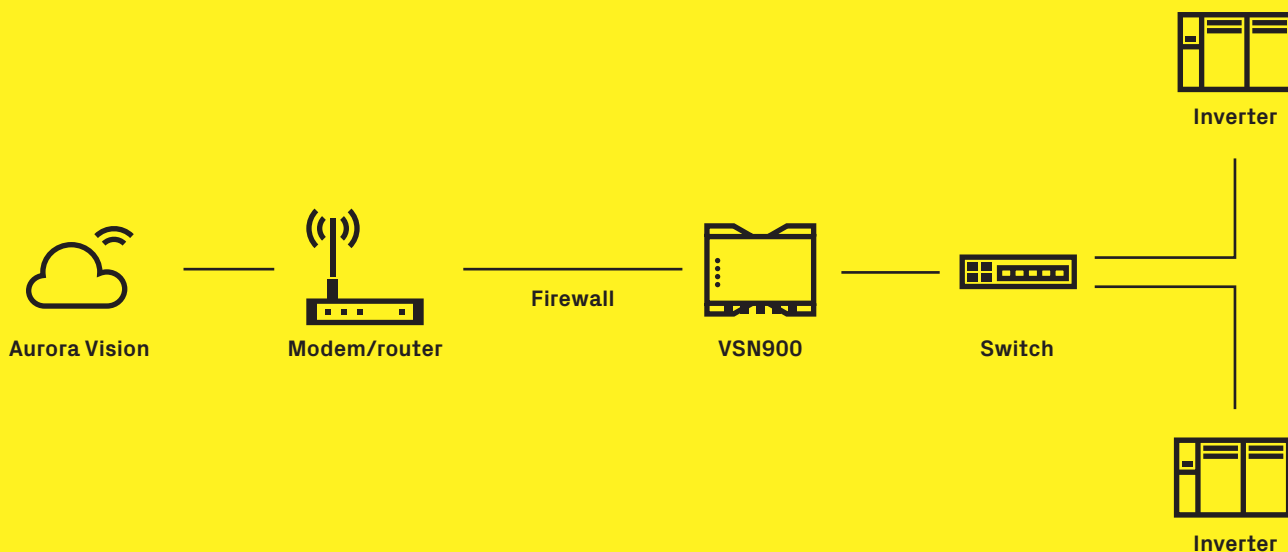

Remote monitoring solutions

Inverter direct remote access

With a built-in web server and standalone data logger, the NETA-21 remote monitoring tool enables secure worldwide access to the inverters. Inverter data can also be collected via 3G/4G mobile connection (modem not included). The remote monitoring tool gives easy access to the inverter via the Internet or a local Ethernet network. NETA-21 comes with a built-in web server. Through the web interface, the user can monitor log data in real-time and access the inverter parameters. One NETA-21 supports up to 10 inverters. The collected data can be stored remotely and utilized for service, maintenance and troubleshooting.

Highlights

- Cost efficient direct monitoring
- Full real-time monitoring of the inverter status
- Scalable & platform-independent remote connectivity

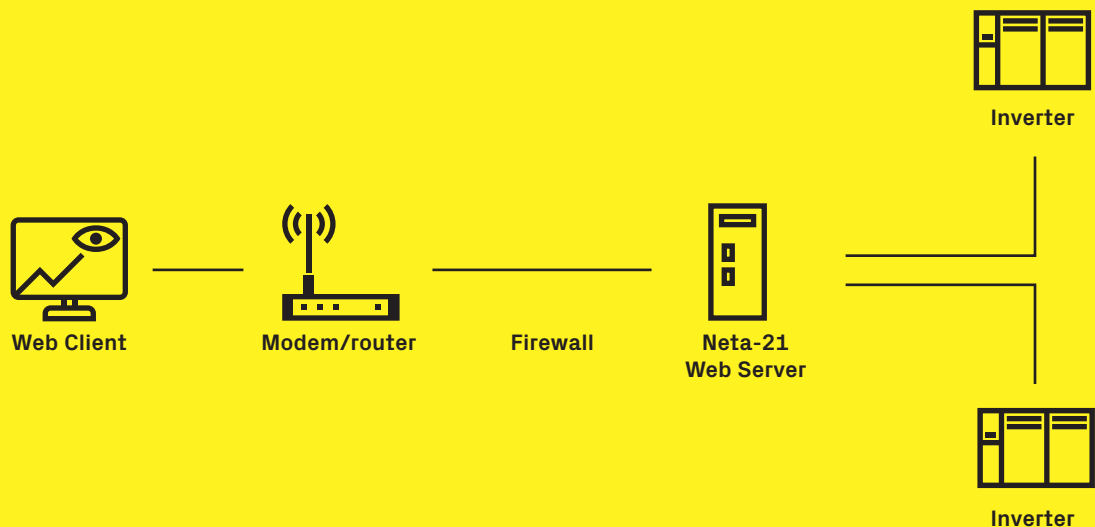

Accessories



Monitoring and communications

VSN800 Weather Station

The weather stations belonging to the VSN800 family allow the monitoring of a series of environmental and panel data through Aurora Vision® cloud platform, being equipped with temperature, irradiation and wind sensors.



The VSN800 contains the essential environmental sensor set needed for solar monitoring. The expanded sensor set allows a wider monitoring of environmental parameters. VSN800 is the perfect companion to the VSN700 Data Logger products and it can directly be connected to the RS-485 port of the new PVS string inverter families.

Shipped preconfigured and ready for installation requiring no special tools

The VSN800 Weather Station is delivered ready for installation and requires the installer to mechanically mount the modules on a user-supplied mast, connect power and communication, and initialize the automatic system commissioning process. No special software, or on-site calibration is required.

The all-in-one weather station reduces the installation, support and maintenance cost while improving the robustness and manageability of the PV plant monitoring solution.

The basic sensor set the VSN800-12 model is equipped with provides data needed to calculate a performance ratio allowing a plant operator to track solar array performance

against expected energy production.

The advanced sensor set the VSN800-14 model is equipped with improves monitoring of weather conditions that can affect energy production. The extra irradiance sensor for mounting at the plane of the array allows more accurate measurement of irradiance that is incident in the plane of the solar panels.

The wind speed and direction sensor gives the operator information about how the wind may be cooling the panels and some indication of how much dust may be accumulating on the panels.

Highlights

- Two models offered for basic and advanced sensor sets
- VSN800-12 includes a basic sensor set: ambient temperature, solar irradiance, and back of module temperature
- VSN800-14 includes additional advanced sensors: plane of array irradiance and wind direction and speed
- Sensors, data acquisition unit, and RS-485
- Can be connected directly to the RS-485 port of the new PVS string inverter families.

FIMER string combiner boxes **SB**

FIMER's offering includes the string combiner boxes SB to ensure the first parallel connection of the PV modules of solar generator modules. Equipped with a robust exterior case, the high-performance boxes guarantee quick and safe installation for outdoor usage and reduce plant downtime.

SB zone monitoring

FIMER's SB zone monitoring combiner boxes are designed for quick and safe installation of centralized solar plants.

Equipped with 20A fuses (30 A available on request), the boxes protect solar panels from overcurrent. The disconnecter of the output and input fuses allows isolating single PV subfields or individual strings from the other parts of the PV system, enabling operators to work safely both during installation and maintenance activities.

Each combiner box is equipped with safety devices as well as a SPD varistor to faults due to overvoltage and lightning.

Highlights

- 1000 and 1500 Vdc combiner boxes
- Possible amount of DC inputs: 16, 20, 24, 32



Technical data

Type code	SB 1010	SB 1210	SB 1610	SB 2410	SB 3210
Combiner box	IA0.595.110	IA0.595.112	IA0.595.116	IA0.595.124	IA0.595.132
Max voltage (V_{cc})	1.000 V				
N° of DC+ input	10	12	16	24	32
N° of DC- input	10	12	16	24	32
Max. input short-circuit current (IscSTC) ¹⁾	12.5 A		13.75 A	12.5 A	
Max. output short-circuit current (IscSTC)	125 A	150 A	220 A	300 A	400 A
SPD protection	SPD Type II 15 kA / 40 kA				
Housing					
Case	GRP (Glass fiber reinforced polyester)				
Door / Opening angle / Lock	Blind /> 120° / Standard				
Housing Dimensions (WxDxH mm)	550x270x650				618x325x822
Weight	16 kg	18 kg	22 kg	26 kg	36 kg
External protection degree	IP65 (outdoor installation)				
Open door protection degree	IP20				
Safety class	Class II				
Colour	RAL 7035				
Environmental data					
Operating temperature	-20° C / +50° C (the cabinet must be kept constantly in the shade) ^{***}				
Storage	-25° C / +60° C				
Height above the sea ¹⁾	up to 4.000 m				
Humidity	0-95% (no-condensing)				
DC input					
Input cable entry	nr 3 PG32 with 4 input each one		nr 4 PG32 with 4 input each one	nr 6 PG32 with 4 input each one	nr 8 PG32 with 4 input each one
Input connection	Directly on fuse holder				
Conductor cross section	4 - 6 mm ²				
Fuse Type	10.3 x 38 - gPV Type curve				
Fuse size (A_{dc}) ^{2) (**)}	up to 25 A				up to 20 A
N° fuse	20	24	32	48	64
DC Output					
Output cable gland ¹⁾	nr 1 PG per pole				
Clamping Area	17-38 mm				
Conductor material	Copper				
Terminal type	Copper bus-bar with M12 screw				
Voltage DC switch	1.000 V _{DC}				
Current DC switch (DC-21B) ¹⁾	200 A		315 A	500 A	

1) Derating of VN versus altitude. 1.0 % per 100 m from 2.001 m to 3.000 m.
1.2 % per 100 m from 3.001 m to 4.000 m.

2) Upgrade to 30 A available on request

(*) Contact factory for different value

(**) Select the fuse ampacity on the base of the rated current and the operating temperature

(***) Contact factory for proper placement

Warnings: to feed the electronic devices of the string box control unit, if present, is required an auxiliary external single-phase power supply 230 V_{AC} (L + N). Please note that the string box doesn't contain blocking diodes.

Remark. Features not specifically listed in the present data sheet are not included in the product.

Technical data

Type code	SB 1215	SB 1615	SB 2015	SB 2415	SB 3215
Combiner box	YVD.F1001.0	IA0.598.116	IA0.598.120	IA0.598.124	IA0.598.132
Max voltage (V _{CC})	1.500 V				
N° of DC+ input	12	16	20	24	32
N° of DC- input	12	16	20	24	32
Max. input short-circuit current (I _{sc} STC) ¹⁾	12,5 A				
Max. output short-circuit current (I _{sc} STC)	200 A				
Rated output current ³⁾	360 A				
SPD protection	SPD Type II 15 kA / 40 kA				
Housing					
Case	GRP (Glass fiber reinforced polyester)				
Door / Opening angle / Lock	Blind /> 120° / Standard				
Housing Dimensions (WxDxH mm)	550x270x650				
Weight	22 kg	22 kg	24 kg	26 kg	36 kg
External protection degree	IP65				
Open door protection degree	IP20				
Safety class	Class II				
Colour	RAL 7035				
Environmental data					
Operating temperature	-20° C / +50° C (The cabinet must be kept constantly in the shade)***)				
Storage	-25° C / +60° C				
Height above the sea ¹⁾	up to 4.000 m				
Humidity	0-95% (no-condensing)				
DC input					
Input cable entry	Cable gland				
Input connection	Directly on fuse holder				
Conductor cross section	4 - 6 mm ²				
Fuse Type	10x85 - gPV Type curve				
Fuse size (A _{DC}) ^{**)}	30 A	Up to 20 A ²⁾			
N° fuse	24	32	40	48	64
DC Output					
Output cable gland ¹⁾	nr 1 PG per pole				
Clamping Area	17-38 mm				
Conductor material	Cu or Al				
Terminal type	Copper bus-bar with M12 screw				
Voltage DC switch	1.500 V _{DC}				
Current DC switch (DC-21B) ¹⁾	400 A	315 A		400 A	630 A

1) Derating of VN versus altitude. 1.0 % per 100 m from 2.001 m to 3.000 m.
1.2 % per 100 m from 3.001 m to 4.000 m.

2) Upgrade to 30 A available on request

3) At operating temperature >50°C there is a current reduction of 1% per °C.

(*) Contact factory for different values.

(**) Select the fuse ampacity on the base of the rated current and the operating temperature.

(***) Contact factory for proper placement.

Warnings: to feed the electronic devices of the string box control unit, if present, is required an auxiliary external single-phase power supply 230 Vac (L + N).

Please note that the string box does not contain blocking diodes.

Remark! Features not specifically listed in the present data sheet are not included in the product.

Remark. Features not specifically listed in the present data sheet are not included in the product.

Life cycle services for solar inverters. Optimizing the performance of your solar plant

The FIMER solar service offering spans over the whole lifetime of the solar power plant. Such optimum support to end users secures the value of the solar power plant assets to the owner.

Pre-sales

FIMER pre-sales support helps our customers to select the right inverter and services for their applications. This ensures higher yield and performance of the entire system and compatibility with customer requirements.

Order and delivery

Orders can be placed through any FIMER office, and spare parts can also be ordered online through the web. Our sales and service network offers timely deliveries worldwide.

Commissioning

FIMER certified engineers can advise or undertake the commissioning of the solar inverters and supervise the installation.

Maintenance

FIMER helps to ensure a long lifetime for its solar inverters by providing on-site preventive maintenance. Preventive maintenance consists of annual inspections and component replacements according to specific maintenance schedules. Reconditioning provides more in-depth maintenance which is carried out at FIMER's authorized service workshops. Reconditioning of the solar inverter includes full inspection, thorough cleaning, individual component analysis and replacement, and complete testing. A service of reactive maintenance is also available.

Upgrade and retrofit

We can advise on the latest hardware and software upgrades that can continue to maximize the performance of your solar inverters even if the grid codes change.

Repairs

FIMER authorized service engineers are standing by to get your equipment back on-line as soon as possible through both on-site and workshop repairs.

Warranty monitoring and extension

The status of your warranty can be monitored online and it is also possible to purchase extensions of the same through the FIMER website.

Life cycle model

The life cycle model divides a product's life cycle into four phases: active, classic, limited and obsolete. Each phase has different implications for the end user in terms of services provided.

Benefits of life cycle management

Life cycle management maximizes the value of the solar inverter and its maintenance investments by:

- Ensuring spare parts and FIMER competence availability throughout the lifetime
- Enabling efficient product support and maintenance for improved reliability
- Adding functionality to the initial product by upgrading or retrofitting
- Providing a smooth transition to new technology at the end of the product lifetime

FIMER Solar Care is a modular set of services for predictable care of your asset and peace of mind over the full lifetime of the solar plant.

The offering includes:

- Availability of spares
- Extended warranties
- Preventive maintenance
- Corrective maintenance
- Response time
- Uptime guarantee
- Training
- Technical support

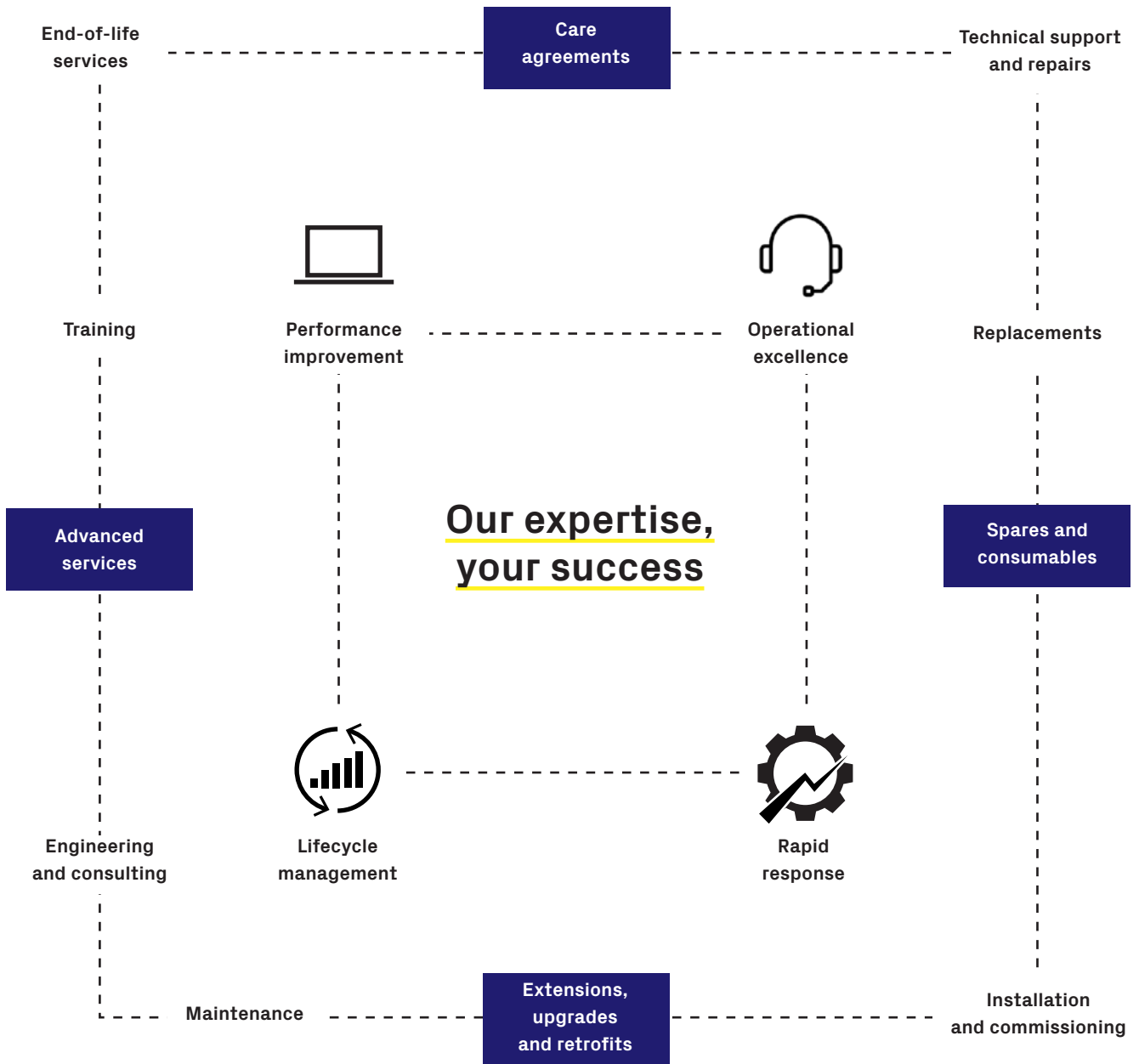

Honoring our Customers globally

Our goal is to commit and invest to reach Service Excellence, through the consistent improvement of our services. Operating in over 100 countries, we are close to our customers, taking care to understand and satisfy their needs.



6 Repair centers



US, Brazil, Italy, Turkey, India and Australia

World-wide partner network



1000 Field Service Engineers including Service Partners

On-site technical support



164 FIMER Field Service Engineers

Immediate availability of spare parts



6 Dedicated service stocked warehouses

FIMER

**Friends
Days**

Take part in **FIMER** **Friends Days**

Become a Certified Installer



Join our exclusive events, discover more about our Solar and EV charging solutions. Enjoy our workshops and have fun with the FIMER staff!

A great experience and exclusive benefits are waiting for you.

Stay tuned on our website!



Visit FIMER through the 360° Virtual Tour Experience

Our Made in Italy excellence is just one click away



We are opening the doors of our Italian establishments to the whole world. Thanks to the 360° virtual tour experience, we are pleased to invite our Customers and Partners to visit us, at any time and with a simple click, through your PC or smartphone, and enjoy an interactive and engaging path.

Visitors will be able to access the Italian branches of Vimercate (Monza Brianza) and Terranuova Bracciolini (Arezzo), visiting the manufacturing sites where our photovoltaic inverters and charging solutions for electric vehicles take shape, and experience first hand - although only "virtually" - the quality of the FIMER branded solutions.

Thanks to advanced Matterport technology we have been able to recreate real-life, external and internal images, of the Global HQ of Vimercate, the modern, zero impact production and Research & Development center, and of the magnificent production site located in Terranuova Bracciolini, at the forefront with regards to the quality of production processes and of engineering excellence.

Last but not least: FIMER's Virtual Tour includes insights of the processes and machineries used during the production phase and a dedicated description of the same.

To log in just register on

discoverus.fimer.com



Shaping the future of energy

For a bright solar future



More than
90%
of our business is solar



We offer more than
12+ GW
solar inverter capacity a year



More than
25 years
of solar experience



The
broadest
solar portfolio on the market

For supercharged electric mobility



Active in electric vehicle
infrastructure since
2017



More than
54.000+
charging stations installed

We have the power to support you.
Count on us

Stronger. Better. FIMER.



FIMER S.p.A.
Via J.F. Kennedy
20871 Vimercate (MB) – ITA

www.fimer.com

